

# **Micro Hydro Quality Standards**

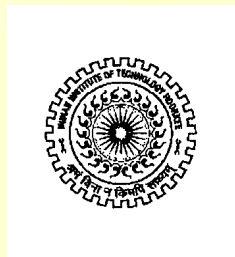

**Alternate Hydro Energy Centre  
Indian Institute of Technology  
Roorkee-247667**

September 2005

# **Micro Hydro Quality Standards**



**Alternate Hydro Energy Centre  
Indian Institute of Technology  
Roorkee-247667**

**Sponsor: Energy Forum, Sri Lanka under USAID(SARI II)**

**September 2005**

## SECTION-1

### INTRODUCTION

#### 1.1 MICRO HYDROPOWER SYSTEM

A micro hydro system is water-driven electricity generation and supply intended to provide a village, hamlet etc. with electricity for various applications such as the following:

- Electricity for lighting and appliances (fan, radio, TV, computer, etc), in homes and public buildings such as schools and clinics
- Electrical or mechanical power for local service and cottage industries
- Electrical or mechanical power for agricultural value-adding industries and labour saving activities
- Electricity for lighting and general uses in public spaces and for collective events

The electricity provided shall be in the form of 415/240-volt AC line connections to users, with 11 kV sub transmission, if required.

The three elements comprising the micro hydro system are:

- *Civil works:* these consist of diversion works, channels and piping to convey river, stream or spring water or canal water to the power generation equipment, the power house building and water exit channel
- *Power generation equipment:* this consists of a turbine, a drive system linking the turbine and a generator and/or mechanical devices, a generator, a turbine and generator controller, switchgear and transformer
- *Power distribution system:* this involves distribution of electrical power by a line system. A line system normally comprises one or more main power distribution lines to central points, then by sub distribution lines and consumer service connections to consumption points.

#### 1.2 SCOPE

The scope of the quality standards includes planning, investigation, design, execution of civil works, manufacture of equipment, tests at works, installation, testing at site and commissioning of power generation equipment including turbine, drive system coupling between turbine and generator and/or mechanical device, generator, generator controller, switchgear and power distribution system; spares for five year operation of the plant; special tools, operation & maintenance etc.

#### 1.3 APPLICATION AND LIMITATION

##### 1.3.1 Size of Installation

Quality control standards cover electricity generation by micro hydropower station up to 100 kW station installed capacity.

##### 1.3.2 Multipurpose Utilization

As far as practicable micro hydro should be multipurpose i.e. domestic and public lighting and other electricity based activities, supply of drinking water, irrigation and other social activity for sustainability.

## 1.4 OVERALL REQUIREMENT

The purpose of the present technical standards and specifications is to optimise the quantity, quality and safety of the electricity services provided by micro-hydro installations so as to meet the societal needs effectively and efficiently. The aim is to achieve the following objectives:

- (i) **Guaranteed Output:** Plant owners and end-users place orders for various items that will satisfy their needs and, in turn, receive what they had ordered from suppliers in terms of available power at guaranteed efficiency.
- (ii) **Reliable Operation:** During a specified service life, the micro-hydro installations should not suffer from frequent outages and need for unanticipated repairs but should provide a high-quality continuous electricity service.
- (iii) **Safety:** Electricity can be dangerous for people, equipment and property even when generated in small plants and quantities. Adequate protection shall be provided, not only at the powerhouse & generating equipment, but also at the consumer end and throughout the electrical transmission (including transformers, surge arrestors etc.). A micro-hydro installation can destabilize and cause collapse or seriously damage hill slopes and associated property due to flooding and overtopping of canals and basins. Therefore, adequate design considerations shall be applied to the water conveyance system and associated structures.
- (iv) **Cost-effectiveness:** The station shall be planned and designed to achieve cost effectiveness.

## 1.5 DISCLAIMER

The Micro-Hydro Standards has been prepared to define the quality requirements of Micro-hydro planning, design, supply and installation works so that competitive bidding for a given set of quality, finish and performance can be called. We accept no responsibility for injury or death resulting from incorrect application or interpretation of the present Standards. The ultimate responsibility for quality, reliability and safety remains with designers, suppliers, installation teams, or operating agencies. It is recommended that design, construction, electrical or mechanical installation, operation, maintenance and repair works be carried out and/or supervised and checked by qualified technicians or engineers only.

## 1.6 NATIONAL STANDARDS AND CODES

All equipment supplied and works executed under these specifications shall conform to the latest edition of applicable Standards issued by National Authorities such as Bureau of Indian Standards, Rural Electrification Corporation Ltd, Central Electricity Authority etc together with any amendment(s) to date. The list of the standards, codes and guidelines are given at Annexure 1. The provisions of State and local statutes, rules and codes as may be applicable shall also be adhered to. The codes and/or standards referred to in these specifications shall govern, in all the cases, wherever such references are made. In case of conflict between such codes and these standards and specifications, the latter shall govern. Such codes and/or standards as are referred to shall mean the latest revisions/amendments/changes adopted and published by the relevant agencies.

## **SECTION-2**

### **CIVIL WORKS**

#### **2.1 GENERAL**

Keeping in view number of households, livelihood, social activity and available energy source, the capacity of proposed micro hydro station is to be worked out. A sample design criteria is given at Annexure 2.

#### **2.2 INTRODUCTION**

**2.2.1** Micro Hydro Projects generally comprises of the following structures. These should be designed and implemented to utilize the locally available construction materials to the maximum extent possible and methods that are simple enough to avoid deployment of heavy construction equipment and highly skilled labourers. Figure 1 shows the general layout of the works of a typical micro hydropower project in hilly area and Figure 2 shows the general layout of the works on a canal.

- i) Diversion Structure
- ii) Water conductor including
  - a) Feeder Channel/ Power Channel including gate.
  - b) De silting tank including trash racks and gate/ valves.
  - c) Forebay tank
  - d) Penstock, anchor blocks and saddle supports.
  - e) Spilling arrangements etc.
- iii) Power house building including machine foundations
- iv) Tailrace channel
- v) Discharge measuring arrangements (e.g. weir)

#### **2.3 DESIGN OF CIVIL WORKS**

##### **2.3.1 General Design Requirements**

- a. A flow duration curve (FDC) shall be established from regular stream gauging during at least two lean seasons correlated to computations using standard methods. For MH plants upto 25kW, spot gauging (min. 2 measurements during lean season) may suffice to establish the design discharge.

The design discharge of micro hydro plants when operating in stand-alone mode should be lower by 10% than the minimum flow derived from the FDC. Hence, the design output would be available all-year round. If this is not possible, adequate back-up power supply, load shedding or other load saving and management methods for the lean season have to be specified as an integral part of the design. Excess water quantities (remaining in the river even throughout the lean season) must be considered according to national laws and regulations.

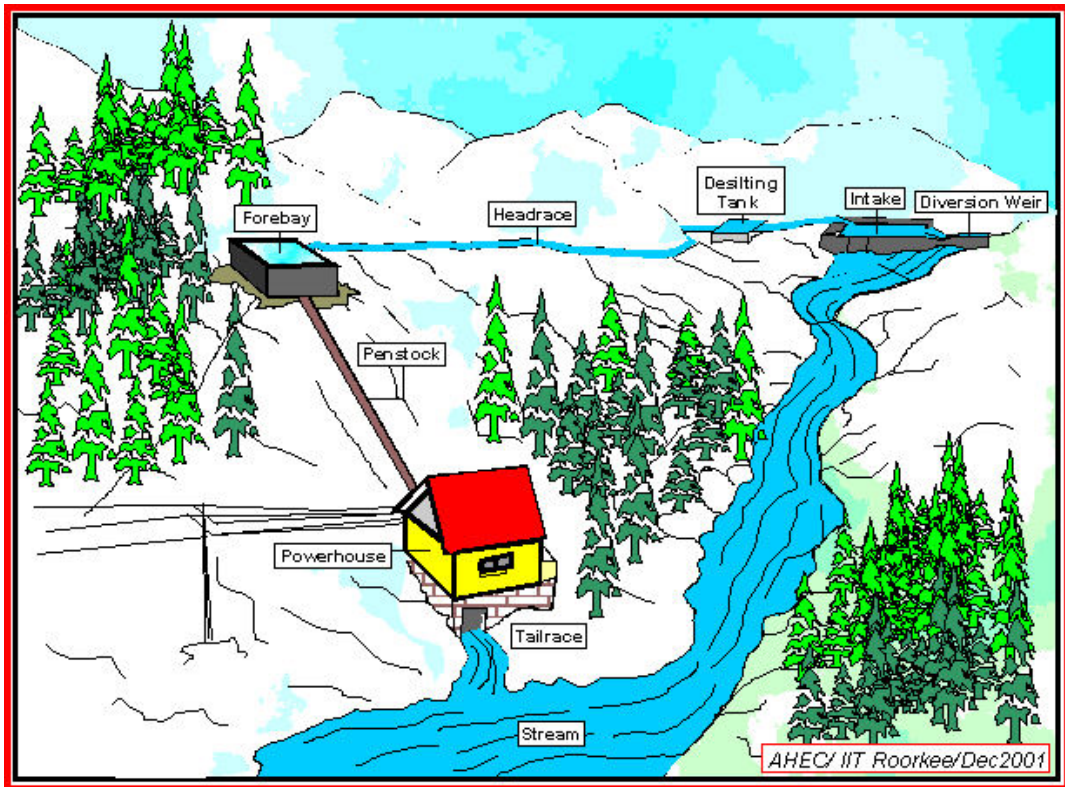

Figure 1 Typical Arrangement of run of river Micro Hydropower project

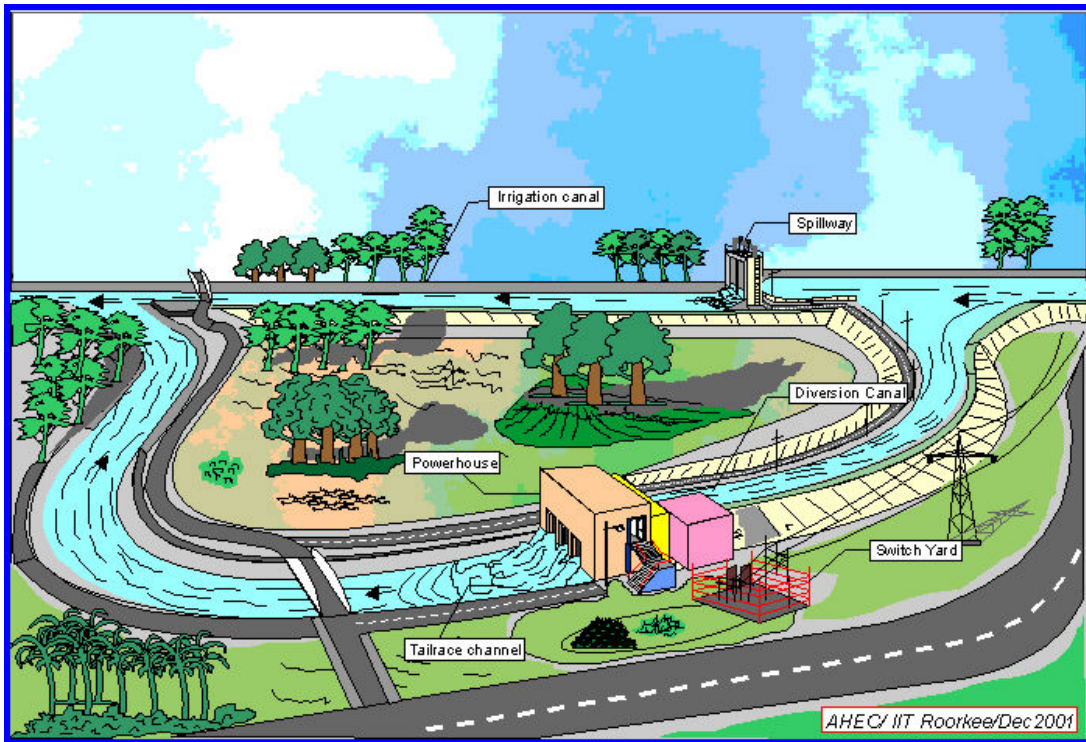

Figure 2 Typical Arrangement of Canal Fall based Micro Hydropower project

- c. The water conductor system (excluding penstock and tailrace) shall be designed for a flow that exceeds the micro hydro design flow at least by 10% in order that the water levels in the desilting tank and forebay are at no instance drawn below the normal design levels when continuously operating the system at full load. The flow requirement for use like drinking and irrigation may be added to the design flow.
- d. A topographical survey of the site shall include a longitudinal profile of the whole water conveyance system as well as cross sections showing geo-technical information, slope stability, gullies and other features. Intervals of the cross sections depend on site characteristics but should typically be between 20 and 50m.

### **2.3.2 Diversion and Intake**

- a. A diversion structure shall be provided for diverting the water from the stream. Figure 3 shows the typical arrangements for diversion weir and desilting tank.
- b. For stream gradients above 5%, a streambed intake is recommended; for all other cases, a lateral diversion is adequate.
- c. The water intake shall be located in the stream or on the river bank in such a way that it can divert the required stream flow at all times and all water levels in the river (may require a weir sill made of boulders/gabion-boxes or stone masonry). The Intake location and design should reject bed load and prevent excessive floodwater from entering the system. The intake and weir should withstand a flood with a return period of at least 10 years for plants with capacities below 25 kW. For all other plant capacities, the minimum return period of the design flood should be 25 years.
- d. An intake orifice (submerged at all times) should be provided so as to reduce the abstracted flow when the river / stream is in flood.
- e. Stop logs shall be provided in order to completely close off the system when required. Complete dewatering of the intake box for cleaning and repair work shall be possible at least during low flows.
- f. Provision shall be made at the intake to exclude large floating debris, and gravel from the diverted water. A coarse trash rack may be used for this purpose.

The above requirements do not apply to spring water sources that never flood.

- g. The Indian standards no. (IS : 7720 (1991), IS : 7114 (1987)) may also be referred.

### **2.3.3 Desilting Tank**

- a. To trap the pebbles and suspended matter, a desilting tank shall be provided. In the initial reaches of the water gravels conductor the velocity of flow is reduced (say 0.3 m/sec) in the chamber to allow the suspended matter to settle down in the bottom of the chamber.
- b. The sediment is flushed out in the valley occasionally through a gated orifice/slucice valve. The desilting tank shall be constructed of brick / stone masonry works or Reinforced cement concrete (M20).
- c. Proper transition flow channel shall be provided. Adequate breast and retaining wall will be provided.
- d. A desilting tank gravel trap and / or sand trap are not required when tapping the springs.
- e. If the source stream carries heavy bed load during floods, a gravel trap shall be provided just after the intake orifice. The gravel sluice gate should be sufficiently large so that

- supercritical flow conditions can be induced in the gravel trap to remove deposits. A gate or stop logs at the intake orifice may be needed to regulate the inflow for that purpose.
- f. In all cases except for low-head installations with  $H_{net} < 10m$ , a sand trap is required. The sand trap shall be able to settle at least 85% of grains larger than 0.2mm for all MHP installations with design heads of up to 100m. For pressure heads above 100m, the settling efficiency for grain sizes above 0.2mm should be better than 90%.
  - g. Longitudinal bed slope of the sand trap should not be less than 1:20 for lateral intakes and 1:10 for streambed intakes. The bed of the desilting tank is to have a trough-like shape in order to facilitate sediment flushing. A sill at the end of the sand trap shall prevent the sand from being washed into to the headrace canal / pipe. A flushing device in the form of timber stop logs, steel slide gate or cylindrical bottom outlet cum spillway shall be provided. The discharge capacity of the flushing gate / valve shall be large enough to completely lower the water level in the desilting tank while maintaining full water inflow for proper flushing.

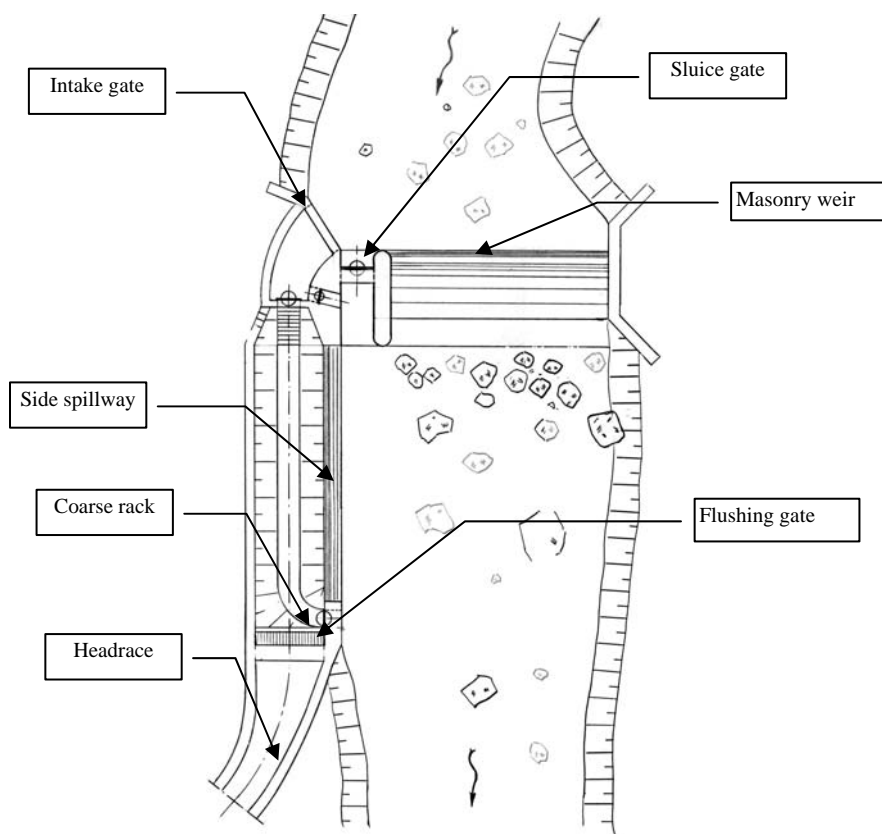

Figure 13: Terminology of a typical diversion weir with desilting tank for a MHP installation  
(Source: Nepalese Micro Hydro Standard, 2004)

#### 2.3.4 Headrace Channel

- a. The water conductor system (Feeder / Power channel) shall be in brick or stone masonry or RCC (M20) or flume or pipe as open channel. The channel may also be unlined by utilizing the existing watercourses with suitable polyester lining depending on the location. The channel shall be plastered from inside using cement concrete ratio 1:3 if the channel is in brick or stone masonry
- b. The requirement of land and problems to be encountered in purchase/ acquisition of land may be one of the guiding factors in deciding the path of water conductor.



- c. The channel shall be covered in slip zones. It shall be provided with adequate cross drainages if required. Adequate breast and retaining wall will be provided. Flood protection works near the feeder channel will be provided as per site requirement as directed by engineer.
- d. Leakage from an unlined headrace canal shall not exceed 5 l/s per 100m of canal length. Unlined canals in silty and clayey soil conditions can meet these requirements. In sandy and gravely conditions, lining with stone masonry or concrete or the use of a headrace conduit will be required to meet the above value. In steep terrain or landslide prone areas, headrace pipes shall be used.
- e. Steel, Plastic, RCC, PCC pipes may also be used as headrace. When using plastic pipes (PVC or HDPE), burying is a must to avoid exposure to sunlight and risk of vandalism. A minimum depth of 0.6 m from ground level to the top of the pipe is to be observed. Steel or cast iron pipes forming a pipe bridge are to be used to cross gullies or landslide areas. The inlet of such a piped section shall be at least 2 pipe diameters below the normal water surface in order to avoid vortices. A coarse trash rack shall be provided at the inlet of headrace pipelines with bends or other local disturbances. For straight pipelines of less than 50m lengths, a trash rack may not be required. The sizing of this coarse trash rack follows the same design requirement as outlined under the heading: hydro-mechanical equipment.
- f. In long headrace canals and/or steep terrain, canal overflow spillways into existing gullies shall be provided along the canal to safely drain excess water without causing water to spill over the canal top and trigger soil erosion.
- g. Provision shall be made to release trapped air along pipelines, which may accumulate during transient conditions or during pipeline filling at pipeline peaks or abrupt changes in slope. At such points, air valves or vent pipes shall be provided.

### **2.3.5 Forebay**

- a. The forebay in the form of a tank connects the headrace to the penstock. The tank may be made in stone or brick masonry, RCC, natural soil or rock duly plastered/protected, wood or steel. It shall house an overflow spillway, a drain valve or stop log gate to flush sediment, a trash rack to intercept floating debris and penstock intake. An overflow spillway and drain valve combined in the form of a cylindrical gate is acceptable as long as its spilling capacity exceeds the scheme design flow by 20%. Permanent structures of overflow spillway and drain shall be continued up to the nearest gully or back to the source stream (as determined by site condition). These may be in the form of conduits or chutes / canals and with energy dissipating structures.
- b. The width of the forebay is given by the required minimum size of the trash rack. The required length of the side spillway gives the length of the forebay. The top of the penstock entrance shall be adequately submerged (approx. 2 pipe diameters) below the normal water surface in order to avoid vortices; in areas with heavy freezing, 0.30m shall be added. The pipe invert shall be at least 0.30m above the forebay floor. Where the forebay acts as a final settling chamber, sediment shall be hindered from entering the penstock by a sill that extends at least up to the top of the penstock. Leakage from the

fore bay shall not exceed 2 l/s in order to avoid soil erosion along the penstock route and around the forebay. The minimum working volume for the forebay tank should be equal to the volume of penstock.

- c. Leakage through the forebay headwall along the penstock pipe shall be prevented by a puddle flange of rubber or mild steel material embedded in concrete. The minimum thickness of the concrete must be 0.25 m.
- d. Mild steel ladder should be provided. Trash rack should be provided at the entrance of penstock. Regular cleaning arrangements and provision of access for trashrack are to be provided.
- e. The Indian standards no. (IS : 7516 (1992) IS : 10 430 (2000)) may also be referred.

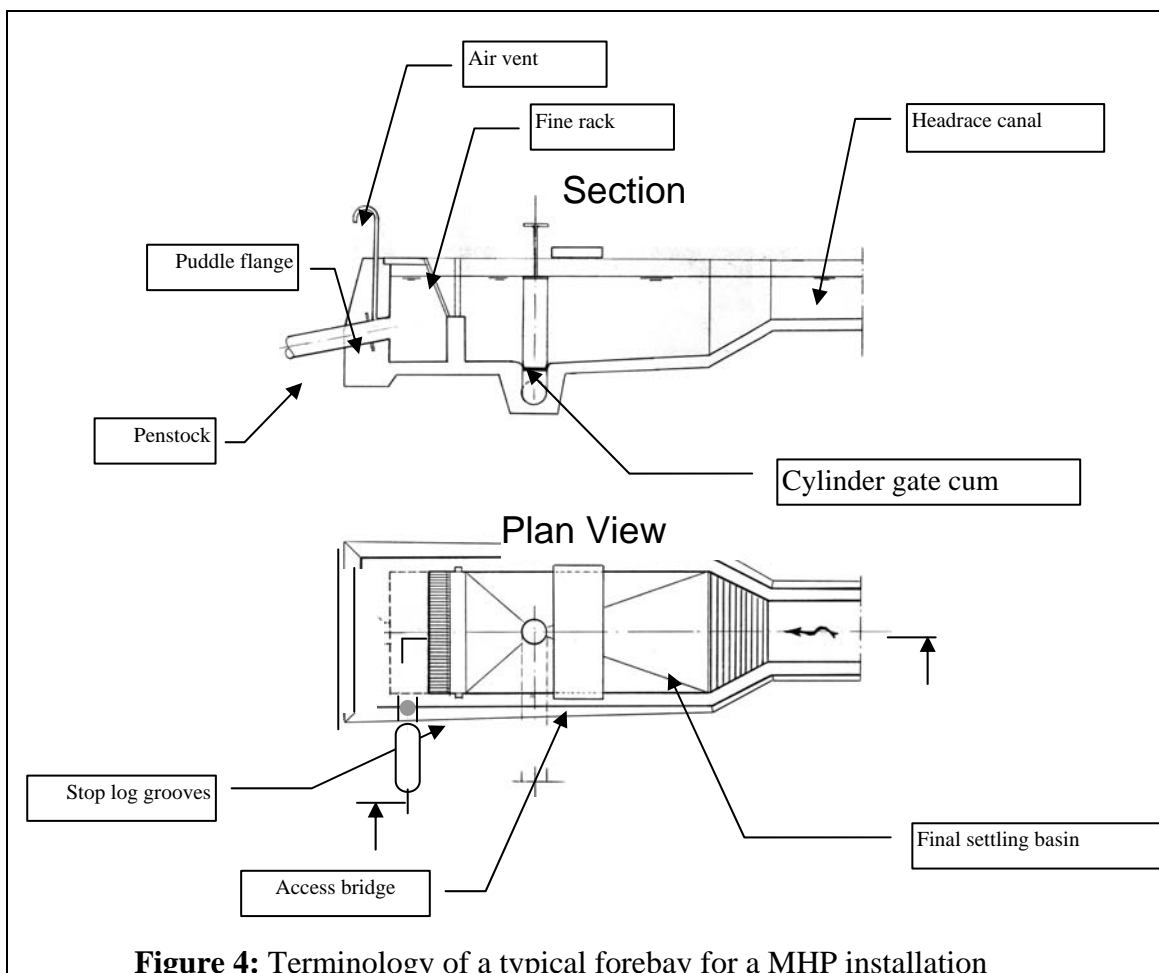

**Figure 4: Terminology of a typical forebay for a MHP installation**

(Source: Nepalese Micro Hydro Standard, 2004)

### 2.3.6 Penstock

a. Penstock pipes shall be provided to convey the water from the forebay tank to the powerhouse under the pressure. It may be made of steel, PVC, HDPE, GRP, PCC, RCC or timber. PVC and HDPE pipes shall be buried at a depth of at least 0.60m from the ground surface to the top of the pipe. In exceptional cases where excavation is not possible and where vandalism can be excluded, HDPE and PVC pipes may be placed above ground with adequate cover. If vandalism is a problem, a steel pipe with a minimum thickness of 5 mm must be used. Buried plastic pipes should be bedded with granular material to avoid point loading. The thickness of such bedding should be no less than 0.1m.

- b. For the penstock having the inner diameter (D)  $> \sqrt{[F*4/(0.25*\pi)]}$ , typically the velocity of flow through the penstock may be designed between 2.5 to 3.0 m/sec.
- c. Penstock pipe diameters shall be selected in such a way that total head loss at design flow does not exceed 10% of gross head including bend and other local losses. Exceptions are acceptable in long penstocks (length more than 5 times the head) if justified on economic grounds. . The head losses of the pipe shall have the provision for friction (generally provided by manufacturers), for deposits and corrosion where applicable. In addition to pipe friction, losses at trash rack (half of it covered with floating debris) pipe inlet, pipe connections (beads, couplings), pipe bends, bifurcations and off-takes, valves, etc. shall be considered.
- d. The pressure rating of pipe and fittings shall be selected in such a way that the static pressure head plus anticipated surge head as determined by turbine guide vane / valve closing time or nozzle blockage etc can be safely accommodated at any point. Instantaneous flow change due to blockage of Pelton nozzles shall be taken as 20% of full flow per nozzle for surge computations.
- e. It must be proven that the pressure wave (water hammer) following valve closure or blockage does not cause damage at any point of the penstock. Ideally the alignment of the penstock shall be steep after the forebay.
- f. In case of corrosive pipe materials, a corrosion allowance of at least 1.5mm for plants with up to 30m gross head and at least 2mm for 30m and above gross head shall be considered. (Painting systems see fabrication section.)
- g. Steel Penstocks should not be buried unless special corrosion protection is applied (see Construction and Fabrication).
- h. Expansion joints may be provided downstream of each anchor block unless other proven means of pipe elongation can be used. Very long penstocks might require additional expansion joints.
- i. Penstock supports and saddles for above-ground GI and mild steel (MS) pipes shall be provided along the length of penstock to adequately support the weight of the pipe and water. These supports may be made of stone masonry or concrete. The penstock pipe must be installed with a rectangular clearance of 30 cm to the ground.
- j. Penstock support structures shall allow longitudinal movement of the pipe due to expansion / contraction with minimum friction. For this, layers of bitumen asphalt sheets or other materials (plastics, greased steel) shall be provided along the contact surface between the penstock and its support. Provision shall be made to drain water (rain or leakage) from the contact surface of pipe and saddle. Clearance between the pipe and the ground surface shall be at least 0.25m as a minimum working space for maintenance.
- k. Hydraulic forces in bends, contractions, expansions and valves, and forces from friction on saddles and temperature differences as well as from pipe and water self-weight shall be securely anchored and transmitted into the ground at adequate distances. 1. An air vent pipe within the first 1-2 metres of penstock length shall be provided so that air trapped in the penstock during filling can be released. The size of the air vent may be about 1 to 2 percent of penstock cross sectional area.
- m. Air valves shall be provided at all peaks or abrupt changes of slope along the penstock.
- n. Bell mouth at penstock entrance shall be desirable.
- o. Water hammer study shall be done if the length of the penstock is more than 5 times of head for reaction machines
- p. In areas of freezing temperature the drain valve shall be provided in the penstock near power house to avoid bursting.

- q. The penstock should be thoroughly cleaned and all left out construction material like stone, welding rods, etc should be flushed out before coupling to the turbine manifold.
- r. The Indian standards no. (IS : 11625 (1986) IS : 11639 (Part 1) (1986), IS : 5330 (1984) may also be referred.

**2.3.7 Powerhouse Building**

- a. A powerhouse shall house the generating and control equipment and shall protect from adverse weather conditions and prevent access by unauthorised persons. These requirements can be achieved through a proper powerhouse with lockable door and leak proof roof or alternatively with a cabinet whose side or top covers can be opened to access the equipment. A semi-open powerhouse is not permitted. A surface drainage system shall be provided in and around the powerhouse. The powerhouse shall be ventilated, have windows for adequate daylight and insect screens at openings. The powerhouse door shall be large enough to allow safe passage of the equipment to be installed in the powerhouse. There shall be provision of a flat and dry floor area inside or outside the powerhouse as a working space for repair and maintenance of the generating equipment. A separate storeroom for spare parts is to be provided in the powerhouse or in a nearby building. A rest room for the operator is only required in those installations where the equipment is not designed for unattended operation. Availability of natural light during the day should be adequately provided.
- b. The elevation of the powerhouse shall be well above any known flood water level of the stream. For plant sizes below 25 kW, the design flood shall have a return period of at least 25 years. For plants above 25 kW capacities, the return period shall be 50 years.
- c. For plant sizes of 25 kW and above it is compulsory to provide for a temporary or permanent installation of a hoist for turbine / generator unit installation and repair.
- d. GI and mild steel as well as corrugated iron roofs and wall cladding shall be connected to the earthing system of the powerhouse.
- e. The foundation for the MHP set shall be made of reinforced concrete and shall be designed to withstand at least the short-circuit torque of the generator in addition to the static loading where two units are to be paralleled, the worst-case out-of-phase paralleling torque must be taken into account. Forces from the penstock and turbine isolation valve shall be taken up and transferred into the ground by a powerhouse anchor block made of reinforced concrete and shall not be loaded onto the turbine casing.

Cable ducts in the powerhouse shall be provided with drainage. Slope of the powerhouse floor shall prevent water from entering into cable ducts. Floor and window areas of the powerhouse may be greater than the respective limits given in the table.

Capacity (kW)	Below 25	25-50	Above 50
Floor area (m <sup>2</sup> )	12	25	Depends on the specifications of turbine
Window area (m <sup>2</sup> )	1.2	2.5	

Minimum height between floor and ceiling > 3.0m

- f. The Indian standards no. (IS : 12800 (Part 3) : 1991) may also be referred.

**2.3.8 Tailrace**

- a. In Pelton and Cross-flow installations, the tailrace shall be designed in such a way that the water level is at least 25 cm below the turbine runner at full flow and clear passage all through the tail channel

- b. Provision shall be made for temporarily or permanently installing a rectangular/V-notch weir for efficiency verification of the generating unit where possible.
- c. Energy dissipating measures such as wire crates etc shall be provided at the end of the tailrace if required with adequate protection from the river water.

### **2.3.9 Development Works**

Development works such as, fencing, approach, kachha footpath; protection work shall be provided wherever required. Footpath approach (kachha), to diversion structure, desilting tank, fore bay and powerhouse building shall be provided. Fencing around desilting tank, fore bay and powerhouse building shall be erected. Flood protection work and protection work for slips etc wherever required should be carried out. Steel gate will be provided with fencing. Fencing and gate shall be duly painted.

### **2.3.10 Electric Line Poles and Foundations**

- a. Ground clearance and other details of electrical lines are described under Section 4
- b. Poles of any material shall be designed to withstand wind forces on conductors and poles with wind speeds according to national building codes. Loading cases with ice load or broken wires shall be taken into account where applicable.
- c. Unbalanced forces from conductor tensioning or change in the direction of the line shall be taken up by guy wires or other approved means.
- d. The setting depth of poles in the ground is at least 16% of the pole length.
- e. Guy wires are to be anchored in the ground by galvanised steel plates; concrete blocks or timber logs which are buried to such a depth that the guy wire forces are balanced solely by the weight of the soil above the anchor.
- f. A top-cap must be mounted on steel poles to prevent corrosion from the inside.
- g. For LV overhead lines in systems where neutral is connected to ground, the neutral wire must be placed on top.
- h. MV line poles must be treated wooden poles (road access available) or local hard wood poles or mild steel poles. In case of metallic poles, a minimum 2 mm thick mild steel galvanised pole or minimum 3 mm thick mild steel pole red oxide primed and painted.

### **2.3.11 Trash Rack**

- a. A coarse trash rack may be provided at the intake and upstream of headrace sections. Bar spacing should be 50mm to 100 mm depending on of trash size.
- b. The penstock intake shall have a fine trash rack. The water velocity through the trash rack at design flow shall be less than 0.5m/s; the surface area to be considered is the net opening.
- c. The trash rack may consist of thinly spaced vertical steel bars or rods (or a perforated plate with holes or slots). The distance between bars or the width of wholes or slots shall not be larger than 0.5 times the nozzle diameter in case of Pelton turbine with fixed nozzle, 0.5 times the maximum clearance in a Pelton nozzle with needle valve or 0.5 times the distance between runner blades for other turbine types.
- d. Structurally, the trash rack shall withstand the full water pressure of a completely blocked rack with maximum water level upstream and no water downstream. A trash rack shall be divided in sections in order to enable manual transportation.

- e. The trash racks should be placed at an angle of around 70° to the horizontal for ease of cleaning and end above water level. A suitable trash-cleaning tool must be provided.

#### **2.3.12 Gates**

- a. For design flows of more than 100 l/s, stop log gates are not allowed as main intake gates, which have to be closed under flowing water and emergency situations.
- b. Simple sliding gates without spindle or other hoisting device shall not be used for gates larger than 0.5m wide and 0.5m deep.
- c. Structurally, sluice gates shall withstand full water pressure upstream and no water downstream.

## **SECTION-3**

### **ELECTRO- MECHANICAL EQUIPMENTS**

#### **3.1 GENERAL TECHNICAL REQUIREMENTS**

##### **3.1.1 Instruction Manuals**

Instruction manuals complete in all respects shall be submitted before the shipment of the equipment by the manufacturers. The instruction manuals shall contain full details and drawings of all equipments furnished, testing, operations and maintenance procedures etc. separately for each equipment.

##### **3.1.2 Spare Parts and Site Consumables**

###### **3.1.2.1 Spare Parts**

The recommended spare parts required for 5-year operation are to be procured along with the original equipment. All spare parts to be supplied shall be interchangeable with the corresponding parts of the Works and shall be of the same material and workmanship. They shall be replaceable without cutting or destruction of adjacent components. All spare parts shall be protected against corrosion and shall be marked with clear identification labels. Suggestive list is given at annexure 3.

###### **3.1.2.2. Tools**

The required tools for normal operation and maintenance be procured. Suggestive list is given at annexure 4.

###### **3.1.2.3 Site Consumables, Lubricating Oil and Lubricants for First Filling**

All lubricants, hydraulic oil, cooling liquids and other liquids shall, in order to minimise the risk of water pollution in the event of a spill, be free of poisonous substances and preferably be biodegradable.

#### **3.1.3 MANUFACTURING REQUIREMENTS**

##### **3.1.3.1 Materials**

All materials used, shall be new and of first class quality free from rust, defects and imperfections. Materials of limited shelf life shall not be used after their expiry date.

Casting shall not be warped or otherwise distorted. The structure of the casting shall be homogeneous and free from excessive non-metallic inclusions. An excessive segregation of impurities or alloys at critical points in a casting will be cause for its rejection.

### 3.1.3.2 Welding

All welding (except welding of thin plates or piping of small sizes) shall be performed by electric-arc method and where practical, with process controlled automatic machines. Butt welds welded from one side only, shall be provided with back strips on the whole length of the seam to be welded.

Particular care shall be taken in aligning and separating the edges of the members to be joined by butt-welding so that complete penetration and fusion at the bottom of the joint will be ensured. Where fillet welds are used, the members shall fit closely and shall be held together during welding.

Where possible, welding shall be carried out in the workshop. After being deposited, welds shall be cleaned of slag and shall show uniform sections, smoothness of weld metal, feathered edges without overlap, and no porosity and clinker. Where weld metal is deposited in successive layers, each layer shall be thoroughly peened before the next layer is applied. Visual inspection of the ends of welds shall indicate good fusion with the base metal.

All welds transverse to the direction of flow shall be ground flush with the plates on the inside. Welds shall be ground flush on both the inside and the outside wherever dynamic stress occurs.

**Welding Qualifications:** For welding of principal stress carrying parts, e.g. penstock and turbine runners the standard of welding procedures, welders and welding operators shall conform to standards and qualifications to national standards or equivalent like the AWS Standard Qualification Procedure.

All welders assigned to the work shall have passed a performance qualification test. If more than one year has elapsed since the welder passed his last test, then he shall again be tested.

### 3.1.4 Protection of Machined Parts at Manufacturing Works

#### 3.1.4.1 Protection of machined surfaces against damages

Finish machined surfaces of large parts shall be applied with anti-corrosive paints and protected with rubber sheet and wooden pads or other suitable means against damages during handling and transportation. Un-assembled pins or bolts shall be oiled or greased and wrapped with moisture-resistant paper. Large size bolts and studs shall be wrapped by polythene tapes.

#### 3.1.4.2 Protection of surfaces against corrosion

All steel and structures parts including steel poles shall be provided with self-priming epoxy based paint as per REC specification 51/1987.

**Bolts, Screws, Nuts etc.:** All bolts, studs, screws, nuts, and washers shall be as per ISO metric system. Mild steel bolts and nuts shall be of the precision cold forged or hot forged type with machined faces parallel to one another

**Seals:** Rubber seals shall be made of synthetic rubber suitable for particular application and shall be designed in such a manner that they are adjustable, water tight and readily replaceable.



### 3.1.5 PIPING, FITTINGS, VALVES AND GATES

**3.1.5.1 General:** All required piping shall be furnished complete with flanges, joints, expansion joints, gaskets, packing, valves, drains, vents, pipe suspensions, supports, etc. Flanged joints or connections shall be provided only as required for transport, installation or for dismantling and reassembly. Standard metric flanges and connections shall be used for all pipe works.

Water, air and drain piping less than 25 mm nominal bore shall be of galvanised heavy grade to IS-1239, Part-I or equivalent standards steel pipe. Pipes equal to or greater than 25 mm nominal bore shall be galvanized heavy grade to IS:1239 part 1 (2004) and IS:1239 part 2 (1992), IS:3589 (2001) or equivalent.

**3.1.5.2 Pressure Testing:** All pressure piping including penstock shall be pressure tested at a pressure 50% greater than maximum operating pressure after erection and cleaning but before painting at site. The test pressure shall be maintained without loss for half an hour. At the site where this is not possible, the penstock pipes shall be tested at works for 1.5 times the normal pressure including water hammer. All the peripheral joints made shall be Dye Penetration (DP) tested for low/medium Heads( below 40 m)and radio graphed for High Head sites (above 40 m).

**3.1.5.3 Valves & Gates:** Generally, valves shall be leak-proof in either flow direction (except for non-return valves) when the nominal pressure is applied. All valves with design pressures higher than PN 10 and diameters larger than DN 100 shall be workshop-tested for tightness and soundness of materials. Valves shall close clockwise and be provided with position indicators/marks on hand wheel. All the sluice valves shall be preferably with rising Spindle. This will give a clear idea to the operator that valve is opening or closing.

**3.1.5.4 Mechanical Instruments:** All mechanical parts of instruments shall be suitably protected against shocks and vibrations, heat, humidity and splash water, etc. Pressures gauges shall be provided with a damping liquid, e.g., glycerin, to compensate vibrations. Pressure gauges without damping means are not permitted.

### 3.1.6 ELECTRICAL WORKS

#### 3.1.6.1 General

Unless otherwise agreed, ratings of main electrical works as selected or proposed whether originally specified or not, shall generally include a safety margin of 10%.

All Works shall be suitable for the prevailing climatic conditions and insensitive to any signals emitted by wireless communication equipment.

**Clearances:** The layout of the equipment in the powerhouse shall provide ready access for operation and maintenance whilst the remaining sections of equipment are alive. Working clearance provided between isolated equipment and nearest live metal work shall be as per Indian Electricity rules & Standards. The clearance of the power panels from walls shall be as per electricity rules (e.g. shall be less than 25 cm or more than 75 cm).

### 3.1.6.2 Electric Motors

**General:** All motors shall be of approved manufacture and conform to IS: 325 (1996) induction motors. AC motors shall have squirrel cage type rotors. The insulation of all the motors shall be of class F but temperature rise during operation shall be limited to class B insulation. It shall be suitable for operation in damp locations and for occasional contact with corrosive gases/vapors.

The direction of rotation shall be clearly indicated on the cover towards shaft extension.. For earthing purposes, each motor shall have adequately sized two bolts with washers at the lower part of the frame. In addition, each terminal box shall contain one earthing screw.

All motors shall be of the totally enclosed fan-cooled type, protection class IP 54. Cable termination points shall be of class IP55.

**Terminal Boxes and Earthing:** The terminals, terminal boxes and associated equipment shall be suitable for terminating the power cables suitably. The terminal boxes shall be of ample size to enable connections to be made in a satisfactory manner. A permanently attached connection diagram shall be mounted inside the terminal box cover.

### 3.1.6.3 3.1.6.4 Moulded Case Circuit Breakers

All moulded case circuit breakers shall be of 2 or 3-pole type as required and IS marked. The breaker will have thermal time delay and instantaneous trips with "On-Trip-Off", indicating/operating mechanism. Circuit breakers used in combination type motor starters or contactors shall have the operating mechanisms interlocked with the starter or contactor cover so that the cover cannot be opened unless the circuit breaker is open.

### 3.1.6.5 Equipment Wiring

All wiring connections shall be readily accessible and removable for test or other purposes. Wiring between terminals of the various devices shall be point to point. Multi-conductor cables shall be connected to the terminal blocks in such a manner as to minimise crossovers

### 3.1.6.6 Cubicles and Control Panels

Cubicles and control panel enclosures shall be of sheet steel with minimum thickness of 2.0 mm, vermin proof, rigid self-supporting construction and supplied with channel bases. Cubicles shall be fitted with close fitting gaskets and hinged doors capable of being opened through 180 deg. The doors of all cabinets/panels shall be provided with similar integral lock and at least six (6) number of master keys shall be supplied.

The cables and wiring shall enter from bottom or top as necessary for the layout through cable glands. The cubicles and panels shall be adequately ventilated by vents or louvers. Space heating elements with thermostatic control shall be included in each panel.

Unless stated otherwise, all cubicles and panels shall be provided with a ground bus with copper bar extending through out the length. Each end of this bus shall be drilled and provided with lugs for connecting ground cables.

All instruments, control knobs and indicating lamps shall be flush mounted on the panels.

### **3.1.6.7 Earthing**

Provision shall be made for earthing all equipment intended for connection in an A.C. mains supply. All structural metal work and metal chassis shall be connected to earth. Earthing conductors shall be at least equal in cross-sectional area to the supply conductors and shall be capable of carrying the fault current.

### **3.1.6.8 Single-Line Diagrams**

Each switchgear shall be furnished with a copy of the final as-built single-line diagram detailing all electrical data and denominations, separate for each individual switchgear/distribution board/MCC, placed under glass and frame mounted at an approved location. The same applies to the Station Single-Line Diagram one copy of which shall be arranged in the control room.

## **3.1.7 INSTRUMENTATION AND CONTROL EQUIPMENT**

### **Design Criteria**

All instruments shall be of IS or equivalent standard mark Shielded cables shall be provided for the control and supervisory equipment where required.

**Measuring Systems:** Electric measuring signals of 4-20 mA or  $\pm 5$  volts DC shall be transmitted to the control room for essential or regulating circuits. Measuring signals for indicating purposes will be 4-20 mA or  $\pm 5$  volt DC. Measuring ranges of indicators, transducers, etc. shall be selected in such a way that the rated value of the measured magnitude covers approx. 75% of the range.

All local instruments shall, as far as practicable, be mounted vibration free to allow good reading. Wherever required, damping elements shall be used. Corresponding systems shall be grouped together in local panels.

### **3.1.7.1 Temperature Measurement**

Platinum Resistance thermometers of type Pt 100 shall be used. The use of dial-type contact thermometers shall be restricted to bearing metal temperature measuring. Resistance thermometers shall be equipped with waterproof connection heads. The temperature sensors shall be selected in such a way to minimise the number of different spare inserts.

### **3.1.7.2 Pressure Measurements**

Pressure gauges shall be shock and vibration-proof (preferably by filling with glycerine) and the movement shall completely be made of stainless steel. The casings shall be dust and watertight and be made of stainless steel. The adjustment of the pointer shall be possible by means of an adjustment device without removing the pointer from its axle.1

The error for pressure transmitters shall be limited to  $\pm 1.0\%$ .

### **3.1.7.3 Level Measurements**

The liquid level measurements in reservoirs and tanks with atmospheric pressure shall be made by means of capacitance measurement type. The errors shall not exceed  $\pm 1.0\%$  of the total measuring range.

### **3.1.8 EQUIPMENT INSTALLATION**

#### **a) General Requirements**

- i) All construction materials, tools and equipment required for complete installation including control and instrument equipment shall be supplied.
- ii) Erection procedures not specified herein shall be in accordance with the recommendations of the equipment manufactures.

#### **b) Installation Materials**

All materials required for installation, testing and commissioning of the equipment including the embedment, inserts, outdoor bolts, grouting of foundation etc. required for the foundations shall be furnished along with the drawings..

#### **c) Cleaning**

All equipment shall be cleaned of all sand, dirt and other foreign materials immediately after removal from storage and before the equipment is brought inside the power plant building or to other installation sites. All piping and tubes shall be air blown.

#### **d) Equipment Assembly**

Equipment installed under these specifications shall be assembled if transported unassembled. The equipment shall be dismantled and reassembled as required to perform the installation and commissioning work described in these specifications.

#### **e) Instrument Setting**

Indicating type field mounted instruments shall be installed in such a way that center of indicating dial shall be about 1500-1800 mm from operating floor level. Non-indicating type field instruments shall be installed such that operating handle of manifold block/isolating cock comes within 1500 mm from operating floor level.

#### **e) Protective Guards**

Suitable guards shall be provided for protection of personal on all exposed rotating or moving machine parts. All such guards with necessary spares and accessories shall be designed for easy removal and maintenance.

### 3.1.9 Noise Level and Vibration

Under all operating conditions, noise level shall not exceed 85dB (A) unless specified otherwise. Measured at 1 m from the equipment

## 3.2 POWER GENERATION EQUIPMENT

### 3.2.1 Special Requirements

Technical specifications have been grouped in 3 different sizes i.e. Category A - 10kW; Category B –above 10 to 50kW and Category C – above 50 to 100 kW. Special requirement for these three groups are summarized in Table 3.1. Specific technical requirements are given in Para 3.3 for Mechanical, Para 3.4 for Electrical and Para 3.5 for Power Distribution.

**Table 3.1: Power Generation Equipment Special Requirement**

	Description	Category (Installed Capacity in kW)		
		Category A (Upto 10 kW)	Category B (Above 10kW and upto 50 kW)	Category C (Above 50 kW and upto 100 kW)
Turbine	Types	<ul style="list-style-type: none"> <li>• Cross Flow</li> <li>• Pump as turbine</li> <li>• Pelton</li> <li>• Turgo</li> <li>• Axial Flow Turbine</li> <li>• Francis</li> <li>• Any other turbine meeting the technical requirement</li> </ul>	<ul style="list-style-type: none"> <li>• Cross Flow</li> <li>• Pelton</li> <li>• Turgo Impulse</li> <li>• Axial Flow Turbine</li> <li>• Francis</li> <li>• Pump as Turbine</li> <li>• Any other turbine meeting the technical requirement</li> </ul>	<ul style="list-style-type: none"> <li>• Cross Flow</li> <li>• Pelton</li> <li>• Turgo Impulse</li> <li>• Axial Flow Turbine</li> <li>• Francis</li> <li>• Any other turbine meeting the technical requirement</li> </ul>
	Rated Output at rated head (at Generator output)	Upto 10 kW	(Above 10kW and upto 50 kW) as specified	(Above 50 kW and upto 100 kW) as specified
	Bid evaluation – equalization for shortfall in overall weighted average efficiency	NIL	Each 3% for every 1 percent difference by which rated average efficiency (computed) is lower than the highest weighted average efficiency	Each 3% by which rated average efficiency (computed) is lower than the highest weighted average efficiency
Generator	Types	Synchronous/ Induction - Single Phase/3 phase	Synchronous/ Induction 3 Phase	Synchronous 3 Phase
	Terminal Voltage, frequency	240 V, 1 –phase, 50 Hz	415 V 3 phase, 50 Hz	415 V, 3 phase, 50 Hz
	Make and Runaway withstand	Standard / Special generators designed to withstand against continuous runaway condition.		

	Description	Category (Installed Capacity in kW)		
		Category A (Upto 10 kW)	Category B (Above 10kW and upto 50 kW)	Category C (Above 50 kW and upto 100 kW)
	Insulation and Temperature Rise	Class F/H insulation and Class B Temperature rise		
	Special provision for grid/mini grid operation	Excitation control will have automatic voltage regulator (AVR) and manual control with excitation limits		
Overall Efficiency	Minimum required Weighted Average Efficiency of the turbine Generator set ( $\eta_T \Delta v$ ) $0.50 \times \eta_{T_{100}} + 0.50 \eta_{T_{50}}$	55%	60%	70%
Control and Switchgear and Metering	Controller (Preferable/Micro processor based)	(ELC) Electronics load controller or IGC Induction Generation Controller	(ELC) Electronic Load Controller (preferred) or IGC Induction Generator Controller	(ELC) Electronic Load Controller or Flow Control Governor
		ELC will have provision for selecting reference frequency for load adjustment $50 \pm 2\%$ so that stable micro hydel/mini grid/grid operation is possible		
	Ballast Load of Electronic Load Controller	Air heater/water heater	Water Heater	Water heater
	Inertia and Flywheel	Adequate flywheel should be provided for isolated operation.		
	Switchgear / Earth Fault Protection	MCB/MCCB for O.C. Protection Provide Earth Leakage Circuit Breaker (ELCB)/Residual current operated circuit breaker		
	Monitoring & Protection	Current, voltage, frequency	<ul style="list-style-type: none"> <li>• Current, voltage, frequency</li> <li>• Stator temperature</li> <li>• Over current (stator)</li> <li>• Maximum &amp; minimum voltage</li> <li>• Reverse Power</li> <li>• Over/under frequency</li> <li>• Bearing temperature</li> </ul>	
Metering	As required.			
Grid/Mini Grid	Micro hydel mini grids will be 11 kV and interconnection may be at 11 kV/33 kV grid sub station. All switchgear and equipment will be as REC std. specifications.			

**Notes:**

1. For efficiency of turbine, the performance curves of similar turbines manufactured by the bidder (tested by independent institution) will be provided.
2. Generator will conform to IS:4722 (2001) and single-phase induction generators to IS:996 (1979).
3. Electric load controllers shall be type tested by an independent institution for adequacy, for performance, surge protection, waveform deviation, electro magnetic interference,

emissions of radio noise.

4. Micro hydro for power generation category B & C should have the following provisions:-
  - (i) Parallel operation in local grids whenever available.
  - (ii) Parallel operation with main grid whenever extended.
5. Micro hydropower generating station category B & C having more than 1 unit shall have following additional provisions:-
  - (i) Parallel operation between units at the station
  - (ii) The Governor/Load Controller, AVR should have adequate provision for adjusting the Speed Droop and Voltage Droop for facilitating the Parallel Operation of the Units.

### **3.2.2 General Technical Specifications**

General technical specifications and requirements are given in Para 3.3 for Mechanical components including turbine, drive system, instrumentation, bearing tools etc; Para 3.4 for Electrical components including generators, electrical protection, instrumentation conduits and cables, Lighting, generation controllers & ballast load etc. and section 3.4 for line distribution system as regards cable sizes and lines etc.

### **3.2.3 Equilisation for Differences in Efficiency**

In the comparison of the tenders, the equalisation on account of differences in the efficiencies of various offers will be made on the basis of weighted average efficiency as calculated by the formula given below:

$$\text{Weighted average efficiency (T}_{nav}\text{)} = K1 \times T_{n100} + K2 \times T_{n50}$$

Where  $T_{nav}$  = weighted average efficiency and  $T_{n100}$ , and  $T_{n50}$  are efficiencies at 100 percent, 50 percent outputs at rated head respectively. The highest weighted average efficiency will be the basis for comparison.  $K1$  and  $K2$  are the factors derived from the flow duration curve of the site. (may be adopted as 0.7 and 0.3 respectively)

- 3.2.3.1 The Ex-Works price of turbines and generator with lower efficiencies will be loaded at the rate given in Table 3.1.
- 3.2.3.2 The weighted average efficiency of the turbine will be multiplied by the average efficiency of the speed increaser (pulley system) etc. (if provided) for obtaining overall weighted average efficiency, which will be used for bid evaluation.
- 3.2.3.3 The basis for selection of the offers shall be overall economy to the purchaser considering power house civil works, monetised values of efficiencies, prices of matching generator, prices of power house, crane required, etc. the speed of the turbine and its design shall be such as to result in the installation of the best generating unit at the least cost.

### **3.2.4 Rejection Limit**

The purchaser has the right to reject the turbine if the test value at the rated output is less than the guaranteed value by 2(two) percent or more after allowing for tolerance.

### **3.2.5 Cavitation Guarantee**

The runner shall be guaranteed against excessive pitting/cavitation for eighteen months from the date of commissioning or 8000 hours of operation, whichever is earlier?



### 3.2.6 Commissioning and Acceptance Test

These shall be performed in accordance with IEC 61116 (1992).

### 3.2.7 SPECIAL TOOLS ETC; SPARES AND DRAWINGS AND MANUAL

These shall be provided as per clause 3.3.9 & 3.3.10.

## 3.3 SPECIFICATIONS FOR MECHANICAL EQUIPMENT

### 3.3.1 Manifold

1. **Head loss.** The manifold is the piping or ducting which carries water from the penstock to the turbine inlets and runners. It shall be designed so as not to introduce large additional head losses. Accordingly, rules of thumb for verifying this are:
  - a. do not allow the velocity of the water in the penstock to increase as it passes through the penstock,
  - b. Velocities in manifold straight pipes should not exceed 3m/s; flow velocities in bends of up to 45 degrees should not exceed 2.5m/s; flow velocities in bends up to 90 degrees should not exceed 2m/s; all changes in velocity should preferably be performed in tapered pipe sections.

### 3.3.2 Manifold valve/Isolating valve

**A manifold valve** is a valve at the foot of the penstock and start of the manifold which stops water flowing in the penstock. A manifold valve shall be provided unless.

- a. where it is possible to quickly and safely, and routinely, divert water away from the turbine runner or the penstock inlet in order to shut down the turbine (for example on some low head sites it may be as quick and easy to divert water at the penstock mouth as to close a valve)
- b. if the guide vane of a cross flow or propeller closes off the flow sufficiently.
- c. if a jet deflection system is fitted to a Pelton
- d. if a multi-jet Pelton has valves on every branch of the manifold

**Location.** It must be located inside the powerhouse and be easily accessible.

**Rating.** It must be rated for maximum penstock pressure.

The valve must be of a **slow closing** type (gate rather than butterfly) or have apparatus which reliably prohibits fast closing, such as:

- a. fitting of a second, much smaller, valve in parallel with the main manifold valve; this is padlocked in the open position and kept open when the main valve is closed.
- b. a gearing mechanism to ensure very slow closing

### 3.3.3 Pressure Gauge

A **pressure gauge** should be available in the powerhouse to read water pressure just before it enters the turbine. After long periods such a gauge cannot be relied on to give accurate readings. Nevertheless it is useful as an indication of the penstock filling to full capacity. To take accurate readings of head, for the field tests a calibrated pressure gauge shall be brought to site to replace the installed gauge or a **calibration** carried out on the installed gauge. A procedure for calibration should be described in the operator manual.

The gauge should read approximately **half-scale** at gross head.

### 3.3.4 All Turbines

1. **Balancing.** The turbine runner shall be dynamically balanced at manufacturer's works before dispatch.
2. **Design features.** The turbine must be of a design, which performs efficiently, and reliably in site conditions at minimum cost.
3. **Interior access.** The turbine must be easy to dismantle in situ to allow inspection of jets and runner, and to allow removal of debris from the jets, runner chamber/casing and other parts. The runner must be removable in situ
4. **Air-access.** If the turbine is of a type which demands good air access to a free jet then the turbine installation instructions must ensure that air flow is not restricted for instance by tail water.
5. **Water seals** on turbine shafts. Non-metallic seals shall be provided. Labyrinth seals or stuffing boxes can be used. Rubbing seals, which cannot be regularly adjusted, should not be used.
6. **Bolts** securing the turbine/generator base-frame to the floor and runner inspection bolts must be removable and not subject to corrosion seizure. To ensure this the design must ensure that water is **drained** away from these bolts. The runner mounting bolts shall be of stainless steel.
7. The design must ensure that the turbine **exhaust water** departs efficiently from the runner. For instance if two runners are used on a single Pelton shaft the gap between should be sufficient to allow exhaust water to escape (3 bucket widths minimum).
8. The installation must allow **access** to all sides of the turbine and space to dismantle it, and access for greasing and maintenance tasks should be provided.
9. **Paintwork** must be provided and kept in good condition to avoid corrosion.
10. Turbine flow measurement facility, preferably by a weir, shall be provided to test turbine/generator efficiency. Weir equations and the salt-dilution method shall be used to check calibration of the flow measurement weir. If no weir is fitted, the salt-dilution method between forebay and tailrace to measure flow may be used.
11. Turbines shall be **tested for run-away** speed conditions. This test shall be part of field tests and performed in the presence of the authorising engineer as part of the commissioning and acceptance test.
12. Retaining **bolts** and runner inspection bolts shall be **protected by grease** from corrosion and shall be well drained. These bolts shall be of stainless steel (Corrosion Resistant).
13. **Runner Alignment.** In the case of Pelton and cross flow, the alignment shall be checked by rotating the runner to ensure that it is correctly mounted on the shaft and accurately aligned with the nozzles or water inlet jet.

14. In the case of a Pelton turbine, **splitter ridge and notch radius tolerances** while rotating the runner shall be checked. The axial tolerance on the splitter ridge and the radial tolerance on the bottom of the notch in neither case should exceed **+/- 0.3% of the PCD**.
15. A by-pass pipe of nominal bore of minimum 37 mm around the main valve shall be provided to equalize the pressure at pressure heads above 40 m and valve nominal bores of 250 mm and above.

### 3.3.5 Turbine Case Design

1. Turbine steel casings shall have adequate thickness. Webs or ribs shall be provided as stiffeners to reduce vibration and noise, which can occur with large flat unsupported areas of steel.
2. The turbine should not be noisy nor vibrate in a way that threatens progressive damage. The turbine shall not make so much noise that it is uncomfortable to work near it for long periods.
3. In cases where bearing alignment and jet accuracy depends on adequate tolerances, the case shall be checked for square-ness with a rule, string, and a square.

### 3.3.6 Turbine/generator base-frame

1. The turbine and generator shall be mounted on a single steel fabrication, the base frame, which shall be set into or fixed to the powerhouse floor (separate fixings shall be avoided in order to avoid tension stresses occurring in the concrete floor). This shall be fabricated from angle iron or channel section. A base frame may be omitted if the turbine and generator are close-coupled, that is, their own frames are rigidly connected to each other's.
2. The turbine and generator shall be fixed securely to the base frame in a workshop before installation to achieve correct positioning. This shall avoid problems with bearing alignment and belt tensions during operation. The runner must be easily removable on site.

### 3.3.7 Bearings

1. **Position.** Crossflow runners must be centrally mounted between bearings; Pelton and Propeller runners can be either centrally mounted or overhung.
2. On larger machines, bearings must be selected and maintained to provide a **service life** of 10 years. On smaller machines a service life of 5 years is acceptable.
3. Bearings must be properly **aligned**, either by use of self-aligning types or by adjusting of the bearing housings. There must never be more than two bearings on one shaft. Poor alignment will cause bearing failure and will be evident in the first year of operation of the turbine. The mandatory one-year warranty shall be given to ensure that the manufacturer covers bearing failure costs, and to ensure that correct alignment is established.
4. With the bearing housing open, the bearing **housing** shall be one third full of **clean grease**

### 5. Commissioning Test

1. The bearing must turn freely. (it should be possible to check with a feeler gauge that the rolling element clearance is within the manufacturer's tolerances). The bearings will not rattle.
2. When the turbine has run for some minutes, bearing housing will not be **overheated**. Overheating indicates the bearings are damaged or severely worn and should be replaced.
3. When the turbine has run for two hours, place your hand on the bearing housing; if it is **too hot** to allow you to keep your hand there, the temperature will be over 60 degrees C. This usually indicates that the bearing housing contains no grease or contains too much grease. In the case of some arrangements it may indicate that the bearing is adjusted with too small a clearance or that the two bearings are positioned with excessive axial thrust relative to each other.

### 3.3.8 Drive System

1. The mounting of pulleys on shafts must be done in a manner, which avoids any danger of progressive fretting damage. Taper-lock bushes are recommended.
2. The pulley diameters used must not be smaller than those recommended by the belt and generator manufacturers, in order to prevent over-tensioning of the belt and over-loading of bearings.
3. Pulleys and belts must be sized according to their manufacturers' procedures. Synthetic belt materials shall be provided for all schemes, and must be used on all except very small schemes. Synthetic belts require high tensions, so that only more expensive bearings and shafts capable of accommodating high tensions can be used, and the drive system will demand more careful maintenance.
4. Drive ratios shall be less than 3:1. Ratios of up to 4:1 may be acceptable on smaller schemes (category A).
5. In the case of synthetic flat belts, the smaller pulley shall be crowned, to stop the belt slipping off.
6. Belt tensions shall not exceed recommended values.
7. With the turbine running, the drive system shall be checked to ensure that the belts shall not **slip** or, in the case of flat belts, progress across the pulley.
8. Belts and flexible couplings shall be inspected for any **degradation** such as cracking or stretching, and for alignment.
9. In cases where direct drive couplings are used, the **alignment** shall be checked.

### 3.3.9 Tools

1. The powerhouse shall be with a **set of tools**, which shall be detailed in the operators' manual.
2. The tool locations shall be silhouetted on a tool **display board** such that it is immediately apparent if a tool is missing or in use.
3. For larger schemes a **lifting hoist** (category B & C) shall be provided in the powerhouse.
4. A rechargeable **battery-powered lantern** shall be provided, and this should be always charged or charging.
5. To test for correct **alignments** and runner and case **tolerances**, the basic tools such as a steel rule, a tape measure, some string, a square, feeler gauges, a dial gauge, and a spirit level shall be supplied.

6. For checking alignments and tolerances of belts and turbines, **string and steel rule**, and possibly also a square shall be supplied.

### 3.3.10 Logbook and maintenance manual

1. The powerhouse shall be equipped with a **logbook** to a format that is in accordance with the maintenance / training manual and supplied accordingly.
2. A **maintenance manual** appropriate to the installation shall be supplied (3 copies).
3. The **logbook** shall be supplied and **used regularly** and accurately during operation stage. It is recommended that the logbook location is silhouetted on the tool display board in the same way as the tools (during operation stage).

## 3.4 ELECTRICAL COMPONENTS

### 3.4.1 Labels and Notices

1. All electrical components shall carry **labels** describing their **function**. This applies particularly to switches and protection trips, circuit breakers, and fuses.
2. A **block diagram** showing the overall electrical layout shall be provided and shall be available in the powerhouse, accessible, and durable. It should correspond to the labeling provided.
3. Individual units such as the controller shall have major internal connections and components labeled and should carry inside a **circuit diagram** corresponding to labels.
4. An illustrated **notice in local language** warning people of danger of electrocution shall be provided within easy view, and it shall be durable. It shall contain practical information on **preventing** and coping with **electrocution** and electric shock (e.g. not working standing in water; use of insulated shoes and mats, one hand working, not working alone, etc).
5. High **voltage warning labels** shall be placed on all cabinet doors and terminal covers enclosing equipment operating at above 50 volts.

### 3.4.2 Shielding

1. All **live surfaces and points** shall be fully and reliably **shielded** from human contact. Cables and their connections to units shall be shielded both by conduit and by their insulation, and connections shall be within closed casings. **Door interlock isolators**, to isolate supply when the door is open, shall be provided on control gear with voltages above 50 Volts in order to ensure safe working.

### 3.4.3 Tamper proofing

1. Individual **units** such as the controller box shall be protected against unauthorised tampering and/or **sealed** for access only by designated specialist service technicians.

#### 3.4.4 Maintenance

1. An **electrical maintenance manual** shall be provided in three copies and shall be in place and in use during operation stage.

#### 3.4.5 Earthing

Earthing will be carried out in accordance National Electrical Code.

Typical grounding system is shown in Fig 5 (a) and 5 (b). Pipe electrode method is preferred.

Separate earths are provided for generator neutral, lightning arrestor and ELC.

A ring from 2 separate earths be run 1 meter above floor level on the opposite wall and electrical equipment connected to the ring by 2 separate connections from each earths from the ring. Every metal part should be connected to earth ring by one connection.

#### 3.4.6 Lightning Protection

1. Lightning **arrestors** shall be fitted to protect the powerhouse and consumers. They shall be provided on each phase as follows: One arrestor on the first pole outside the power house, one arrestor per kilometer of distribution and additional arrestors to ensure that no consumer is more than 500 meters from an arrestor. Arrestors shall be installed and earthed according to the manufacturers instructions by separate earths and as per IS: 2309 (1989). They shall comprise horizontal/vertical air terminations, down conductors, test links and earth connections to the station earth. The conductors shall be of 25x6 mm size and shall be mild steel (galvanized).

#### 3.4.7 Over current and Earth Fault Protection

1. **Over-current trip.** Excessive currents in the cabling due to faults such as short-circuits or overloads may damage cables and the generator windings, and create a fire risk. Proper protection, in the form of a MCB (miniature circuit breaker) or MCCB (moulded case circuit breaker) placed as close as possible to the generator terminals shall be provided.
2. **Earth-fault protection (ELCB).** In order to protect people from electric shock at any location throughout the distribution system and in the powerhouse, an earth leakage circuit breaker (ELCB) shall be fitted on feeder as close to the generator terminals as possible. The standard sensitivity for human protection of 30mA should be used except for larger schemes where the number of consumers is so great that cumulative earth leaks due to normal insulation resistance leakage and stray capacitance currents would cause spurious tripping. In this case consumer clusters (typically around 15 houses or 1.5 kW) should be protected by 30mA ELCBs within the distribution system and the powerhouse can be protected by a less sensitive and slower-acting ELCB.

3. **Ratings.** The OC trip and ELCB current carrying capacity ratings should be suitable to carry the current marked on the original nameplate of the generator or motor-as-generator. The maximum rating for the OC trip shall be no more than 10% above the generator current rating.
4. **Location.** The over-current (OC) trip and ELCB can be placed in the same box with each switch clearly labeled. They should not be mounted on the generator body itself to avoid vibration damage. They should be at least one meter above floor level, and as close to the generator as possible, with properly fixed and sealed conduit protecting the cable to the generator (which is not otherwise protected). The ELCB should be connected to the generator and then the OC trip should be connected to the ELCB. In small schemes where the controller box is placed close to the generator the OC trip and ELCB can be included inside the controller box, with switches accessible and labeled. Conduit must be correctly used and the conduit connections sealed. Resetting of trips must be possible without opening the box, to ensure that the box is left locked/sealed in normal operating conditions. This is not necessary if a door-interlock isolator is fitted.
5. **Terminals** and connections for both trips (and all other devices) shall be **checked** for tarnish, loosening, dirt accumulation, moistness, signs of overheating, etc, and procedures must be in place to make good during operation stage.
6. Operators should be able to locate and **correct an earth fault** without undue delay.

#### 3.4.8 Conduit and Cables

1. Strong conduit must be used to **protect all cable** in the powerhouse from vermin attack to the insulation. Knockouts shall also be suitable protected. The end-of-cable terminals shall be protected yanks or pulling. It should be ensured that the conduit is strong and physically secured to all enclosures (trip boxes, controller boxes, ballast, etc) by means of threaded connectors secured to the enclosure, so that any yank to the conduit is not transferred to the cable connections. The conduit shall also be sealed to the enclosure entrances in order to prevent insect and dust ingress.
2. Physical strength of the conduit from **generator to OC trip/ELCB** box should be adequate, as the cable inside it is not protected from over-current and earth faults.
3. **Cable sizing.** Current handling capacities of the cables should be 40% greater than the rating of the over current protection device(s), after taking account of de-rating required for use in conduit and multiple cables.
4. Cables should **not feel over-warm** to the touch. If so, cables are undersized and should be replaced or doubled-up.

#### 3.4.9 Sockets

1. One or more electric **sockets** (outlet) shall be provided to allow use of electrical appliances and tools in the power house; these must be placed at least **one meter above floor** level to avoid danger of water ingress.

#### 3.4.10 Lighting

1. The powerhouse must have an installation-powered electric light fittings which gives adequate **safe illumination** (minimum 10 watts/m<sup>2</sup> of floor area incandescent or 3 watts/m<sup>2</sup> fluorescent).
2. A battery-charging type lantern (“**emergency lamp**”) on the tool display board, in charged or charging state, shall be provided.
3. An installation-powered **light outside** the powerhouse above the door shall be provided.

#### 3.4.11 Powerhouse Consumer Isolation Switch

1. A **switch** allowing the **distribution** system to be **isolated** from the generator and controller shall be provided. This should be located inside the powerhouse and clearly labeled. On smaller schemes the isolation switch can be included in the controller box; on larger schemes it should be in a separate box placed after the controller.
2. The switch must have a current **rating** equal to or higher than the rating of the OC trip.

#### 3.4.12 Voltage and Frequency Trips

1. **Trips** are required to protect consumer loads from unacceptable voltage and frequency conditions.
2. **Overvoltage** trips should be fitted on all schemes
3. **Undervoltage** trips shall be fitted on all schemes where motors are used by consumers and they are fitted on all schemes above 5kW.
4. **Over and underfrequency trips** shall be provided required on all schemes where motors are used by consumers and are mandatory on all schemes above 25kW.

#### 3.4.13 Synchronous Generators and Induction Motors as Generators

1. **Brand.** The brand and power rating of the generator or motor should be approved by the manufacturer of the turbines and by the purchaser.
2. **Nameplate.** The original manufacturer’s nameplate for the generator or motor must be retained. New nameplates can be added but must not replace the originals.
3. **Over-rating.** The power rating given on the original nameplate must be at least 10% more than the scheme rated power.
4. **Generator voltage.** The “power house voltage” is the voltage at the generator terminals with powerhouse-consumer isolation switch in off position. This must be between the nominal national voltage (415 V) and +10% of 415 V.
5. Generator rotational speeds to be selected shall be 1500 rpm (+slip) or lower. In cases of direct coupling 750 rpm or 1000 rpm generators should be preferred.

#### 3.4.14 Synchronous Generators

1. **Frequency.** The operating frequency should be between 47.5 and 52.5 Hz.



2. **Pf.** The power factor rating should be 0.8 when an ELC is in use except where all loads and the ELC present a unity power factor.
3. Brushless generators shall be supplied with regulator (AVR). The unit proposed for interconnection with grid shall have in addition automatic power factor Regulator (APFR) with automatic change over from AVR to APFR when grid interconnection circuit breaker.
4. The generator shall be capable of continuous withstand against runaway speed.

#### 3.4.15 Induction Motors as Generators

1. **Frequency.** The frequency should be between 50 and 52.5 Hz. The frequency should be within this range under all operating conditions, including minimum and maximum power output, zero consumer load and worst-case consumer load power factor.
2. The induction generator must be **over-voltage protected** to avoid excessive currents to flow through the excitation capacitors and induction machine. A protection system is required that disconnects all or some of the capacitors, to limit the currents flowing to below the limits for the induction machine windings and the capacitors. Provide MCBs of suitable current rating in the series with excitation capacitors.
3. The generator shall be capable of continuous withstand against runaway speed.

#### 3.4.16 Controllers and Governors, Flow Regulators

1. Where **synchronous generators** are used, an electronic load controller (ELC), electronic and flow governor should be provided.
2. Where **induction generators** are used, electronic load controllers (induction generator controllers - IGCs) shall be provided so, that voltage is controlled.
3. The controller must be **located** in the powerhouse, together with the ballast, to ensure the ballast is never disconnected.
4. **Instrumentation** should be as specified below 3.4.18.

#### 3.4.17 Ballast

1. **Below 5 kW**, air resistance heaters (cooking rings) shall be provided. Wall-mounted units should be mounted high on a wall but not closer than one meter to the roof.
2. **Above 5 kW**, water-cooled ballasts shall be provided to prevent overheating of the power house.
3. **Location.** The ballast shall be located in the powerhouse to ensure that it is never disconnected and for water-cooled ballasts, water supply should be continuous to the ballast tank.
4. **Cables** to the ballast shall be short to be secure and tamper-proof so that there is no danger of disconnection of the ballast - no method of disconnection must be present.
5. **Reliability of water-cooling.** Every care shall be taken to ensure that the water flow is not impeded or else the ballast will overheat and fail. The design must include reliable protection against the effects of a water flow blockage: Alarms for high water temperature and low water level shall be provided for automatic disconnection of the generator field in the case of a synchronous generator. Ballast tanks should be made from corrosion-proof materials. They should have an overflow channel provided, to direct spill water away from electrical apparatus in the case of an out-flow blockage. An arrangement for easy flushing out of silt deposits shall be provided.

6. A typical reliable hot water ballast system for 2 x 50 kW is shown in Fig. 6.

### 3.4.18 Instrumentation

1. **All instrumentation**, except kWh meters, may be included on the control panel. Instrumentation should be at eye level or 1.5 meters from floor level.
2. **Ballast meter** (indicating power dissipated in ballast). There shall be a method of reading approximate electrical power output in the powerhouse. In 3-phase ELC systems 3 ballast meters, one for each phase shall be provided. Changes in the reading(s) may indicate failure of one or more ballast elements or variations in the power output of the turbine-generator. (The ballast meter gives percent of power to ballast and should be additionally labeled with power to consumer markings. It can be used to show any difference in actual power and commissioned power at any stage of the life of the scheme).
3. **Voltage**. A voltmeter with voltmeter switches shall be provided.
4. **Current**. On a 3-phase system an ammeter on each separate phase shall be provided. For currents of 30 Amps or more, current transformers shall be used for safety and reliability
5. **Frequency**. Frequency meter shall be provided for a scheme above 5 kW. On induction generator systems, a frequency meter shall be provided, to facilitate adjustment of the excitation capacitance and to indicate whether capacitors have failed.
6. **kWh meters**. To record consumer power as total power for scheme above 5 kW.

A typical, metering & relaying for 50 kW set is shown in figure 8

### 3.4.19 Interconnection with Grid

#### 3.4.19.1 Voltage and Frequency Protection Functions

- a This section considers the requirements for grid protection and quality requirements for generator protection.
- b For plants under this standard, three-phase over-/under voltage as well over-/under frequency protection should be provided with suitable time delay relay.
- c Frequency tripping limits shall be chosen in order not to compromise grid stability for local grid. This means that the under frequency value shall be in a range below a defined "load shedding" frequency band in case of a dropping frequency. Load shedding will precede the loss of small generators.
- d Power factor and voltage regulator will be provided in the generator excitation system.
- e A synchronizing check relay shall be provided to avoid wrong synchronizing of the machine.

A typical system for 50 kW set is shown in figure 7.

#### 3.4.19.2 Islanding Protection Functions

- a. Islanding occurs if a grid-connected generator continues to supply an isolated portion of the grid after tripping of a nearby circuit breaker in the distribution grid. This is possible if the load in the grid does not exceed the capacity of the generator.

- b. Every interconnected plant must address the problem of islanding and suitable measures must be taken.

### **3.4.19.3 Islanding protection for synchronous generators within a Smallest Possible**

#### **Island:**

With a single grid-connected generator in a given portion of the distribution system, reliable islanding detection can be achieved by an under voltage/ under frequency protection if the generator capacity is significantly lower than the minimum load in the smallest possible island.

### **3.4.19.4 Additional Protection/Safety Requirements**

- a. Reverse power protection is recommended to avoid continuous motoring of the plant and related loss of energy. Possible reasons of reverse power flow are rupture of flat belts or lack of water. Other possibilities exist to detect such faults.
- b. Additional requirements exceeding the present standard may be possible in individual cases, but shall be avoided unless necessary for operational security or safety.

A typical grid inter connection is shown in figure 7.

## SECTION-4

### POWER SUB-TRANSMISSION AND DISTRIBUTION

#### 4.1 General

Power transmission at 11kV and distribution at 415/ 240 Volts will be in accordance with rural Electrification standards. Relevant list of the REC specification and standard are listed at Annexure 1.

#### 4.2 Voltages

1. The **consumer voltage** shall be between +10% and -10% of the nominal national voltage as per Indian Electricity Rules.
2. Powerhouse **voltage** shall be **adjustable** by tuning of the voltage potentiometer on the controller (induction generator systems) or on the AVR. (Automatic voltage regulator) on synchronous generator systems.

#### 4.3 Distribution Plan

1. A distribution diagram shall be provided for schemes over 5kW capacity which shows **key line distribution information** including:
  - Voltage at power house
  - Cable lengths
  - Conductor cross-sectional areas and materials
  - Max demands at load centres (in amps)
  - Min expected voltages at all nodes and load centres
  - Number of phases for each section
  - Positions of lightning arrestors
  - Positions of isolation switches and ELCBs

This information shall be relevant to operation of the plant at full capacity for maximum loading as expected after some years of demand growth.

2. In **3-phase** systems, the load distribution should be so designed that the phases will be sufficiently **balanced** at all hours of the day.

#### 4.4 Power Factor

1. In **synchronous generator systems**, the power factor should not drop below 0.8.
2. In **induction generator systems**, the consumer power factor should not drop below 0.95 in order to retain frequency control.
3. **Correction** must be added to achieve the limits specified above.

#### 4.5 Earthing

1. Earthing shall be provided as per REC (Rural Electrification Corporation) standards and Indian Electricity Rules.
2. **Earthing** in the powerhouse will be in accordance with the specifications of the ELCB (Earth Leakage Circuit Breaker). It is not compulsory to draw an earth line in the distribution circuit.
3. Where consumer loads are simple appliances such as lights and double insulated non-metal items like radios, no earthing is required other than the powerhouse earth. Where consumer loads may include metal appliances such as irons, water heaters, an earth connection must be installed for each consumer likely to use such loads.

#### 4.6 Isolators, Fuses, ELCBs

1. **All consumer circuits** shall have isolation switches and fuses or MCBs fitted at entry point and these must be clearly labeled in the local language. A well-illustrated electrical safety booklet shall be provided for each household.
2. **Clusters.** If the number of consumers is large, isolation switches shall be provided to clusters of consumers. This will allow a speedier location of earth faults.
3. **ELCBs.** It is usually not cost-effective to fit ELCBs to individual consumer points, but where the number of consumers is large and spurious triggering of a single 30mA ELCB in the power house poses a problem, it is recommended that clusters (typically of around 15 houses or 1.5kW) are protected by 30mA ELCBs. These can be located inside the powerhouse or outside in weatherproof housing: If located outside, it is recommended that the powerhouse be also fitted with an ELCB the sensitivity and response time of which is reduced.
4. Location of **earth faults without undue delay is required.** This may be done through ELCB. If the powerhouse ELCB trips the first step is to isolate the powerhouse and then restart the generator. If the ELCB stays untripped the fault is in the distribution system, and the next step is to isolate clusters of consumers or all individual consumers. Progressive switching in of consumers will reveal the location of the fault.
5. It is recommended to install a single 150 mA or less ELCB at the powerhouse to protect each circuit drawn from the powerhouse. A single 30 mA ELCB may be installed at the load points, which use loads more than 1kW.

#### 4.7 Load Limiters

1. Appropriate **MCBs** (0.5 A for 100W and 1A for 200W) are recommended to be installed at the load points. 1mm<sup>2</sup> size PVC insulated cables are recommended for house wiring if the maximum load used by the house is less than 200 W.

## 4.8 Cables

**Material and Strength:** Aluminum, copper, ACSR and high strength aluminum alloy cables are recommended. **Underground cables** are **not** recommended due to cost of their installation and consideration of safety. Insulator materials should not deteriorate over time.

1. **Insulation and Clearance:** For Overhead lines (OH) the minimum ground clearances are 5.8m across motorable roads, 5.5m beside motorable roads and 3m over open ground. The minimum horizontal and top clearance shall be 1.5m. It is recommended that insulated cables be always used in heavily vegetated or forested areas. Twin sheathed cables are recommended for use as service wires. Recommended sags and tensions of the cables, size of the poles, Insulator types, etc., are given in the REC construction standards.
2. **Conductor Sizing:** Details pertaining to the selection of conductors are provided in the REC construction standards. Different sizes of conductors could be used for a single project.
3. **Conductor Spacing:** The spacing should be 300mm between conductors for a vertical arrangement of OH conductors with the neutral lowest.
4. **Joints:** All joints must be durable, adequate for their purpose, mechanically strong and visible. Bi-metallic clamps are recommended for joint, which connects dissimilar metals. Connections should not be loose; otherwise the terminals get hot and result in loss of power.

## 4.9 Type of Poles

1. **Materials.** Distribution cable should be drawn on poles made from hardwood, reinforced or pre-stressed concrete or galvanised steel pipes. Also trees are recommended to be used as poles, where care can be taken to ensure safety.
2. Steel and wooden poles should be **treated** or **painted** for longer life.
3. **Dimension and spans:** 7m high poles should be used for insulated cable network, up to 10mm<sup>2</sup> cable size. Above 10mm<sup>2</sup> and up to 35mm<sup>2</sup> size cables, 9m poles should be used. For un-insulated cables and bundled cables 9m and 13m poles should be used.
4. **Span of the poles - Single Phase system:** Span of the poles will depend on the terrain. Up to 16mm<sup>2</sup> insulated wire- 2 core, maximum span shall be 30m. Above 16mm<sup>2</sup> and up to 35mm<sup>2</sup>, max. Span shall be 25m.
5. **Span of the poles –Three-Phase system:** For bare conductors AAC or ACSR use REC National Standards for span & length.
6. **Type of Insulators:** For insulated cables Nylon bobbins or telecom insulators as partial insulation. For bare cables, LT insulators are recommended. For the connection of those insulators, refer the REC standards.
7. **Stays:** Stays must be used at the first and last pole of straight line and at any turns.
8. **Span and Sag:** See REC standards/Annexure 1 for details.

#### **4.10 Lightning Protection**

**Arrestors**, as described in the specifications for electrical components clause 3.4.6.

#### **4.11 L10 House Wiring**

1. Load limiter of 0.5 A **MCB** should be installed as the incoming protection device for the installations of 100 W. For 200 W 1 A **MCB** should be used. For other loading appropriate MCB to be installed as the main incomer.
2. In installations up to 1 kW, 1 circuit with 1 mm<sup>2</sup> cable can be used. The wire shall be of 600 V grade insulation.
3. Conduits shall be used wherever mechanical protection is needed. Running on the roof section the wires can be clipped on to the wooden parts.
4. Switches shall be standard switches, which are designed for 230 volts.

## **SECTION-5**

### **INSTALLATION, OPERATION & MAINTENANCE**

#### **5.1 INSTALLATION AND COMMISSIONING**

##### **5.1.1 Hydro-mechanical Equipment**

- a. The completed penstock shall be pressure tested in the field. All joints shall be left open for visual inspection. A test pressure of 1.5 times the static working pressure shall be applied and held for 24 hours. Concrete anchor blocks shall be at least 7 days old before any pressure testing is conducted. Welded sections in the concrete block should be tested at works. Testing can be done separately for each section.
- b. A final painting check must be performed on all site welds and spots with damaged painting prior to backfilling.
- c. The penstock shall be flushed prior to conduct turbine test-runs, or other suitable methods must be used to free the penstock from stones and sediments. Care must be taken not to create pressure shocks when flushing. On the other hand, significant flow is often needed to move stones out. (Not applicable when inside visual inspection is possible)

Penstock filling shall be carried out with a flow rate of about 10% of design flow.

##### **5.1.2 Electro-mechanical Equipment**

- a. All power and control cables within the powerhouse shall be laid in covered cable ducts or on cable trays along the wall / ceiling or in cable trenches as appropriate. All cables in the powerhouse shall be either armoured or be placed in protective conduits. All connections must use proper cable shoes and all cable traverses at generator or control panel must use safe cable glands to avoid any damage of the isolation.
- b. It shall be re-checked and confirmed during installation that fuses / breakers are of adequate type and size and fit in the network of power / control circuits so as to provide optimum protection from overload / short-circuits.
- c. The following tests should be conducted, duly recorded and certified by the commissioning engineer. The concrete works should be at least 28 days old for testing and commissioning.
  1. Checking mechanical and electrical protection systems, generator phase rotation test, insulation tests of cables, generator and transformer, braking system where applicable
  2. First rotation up to 20%, 50%, 100%, 120% rated speed using a tachometer. Disable excitation if possible and make sure that the generator is electrically disconnected.
  3. No-load test with AVR / excitation tests
  4. Loading tests (load acceptance, load rejection, output test, stability of controller, governor)
  5. Optional: Efficiency test water to wire using calibrated test ballast and instruments.



- d. The overall efficiencies (water to wire / electrical output of generator) to be reached during commissioning shall be as per table 3.1.

## **5.2 OPERATION AND MAINTENANCE**

Note: Supplier's maintenance manual takes precedence over the following rules. Rules in this standard shall be applied where no indications are given by the supplier.

- a. A manual comprising a detailed description of the operating procedures and maintenance tasks as well as detailed drawings of all components in local language (or English) must be compiled by the design engineer. The following specifications must be included.
- b. Address and phone number of suppliers and sub-suppliers for spare part ordering and guarantee claims.
- c. Technical description and specifications relevant for operation & maintenance.
- d. Lubrication table and required lubricants for all bearings, gates etc.
- e. Operation instructions for start-up, shut down, emergency.
- f. Checklist for normal operation (bearings, instruments, belts, coupling rubbers, noise, vibrations etc.)
- g. Check list for fault detection and communication with manufacturer
- h. Sample (master copy) for operation sheet for the operator (data, instrument readings, observations, reading interval, remarks and signature)
- i. Sample (master copy) for maintenance sheet for the operator (lubrication intervals, check interval, signature)

Wiring diagram of power-station with description of all fuses (type, size)

### **5.2.1 Civil Works and Hydro-Mechanical Equipment**

- a. The entire water conveyance system must be drained once per year for cleaning and to check for erosion damage around structures, cracks and settlement in concrete and masonry structures, leaks in canals and basins and corrosion damage.
- b. Movable parts such as gates and hoists shall be greased regularly and test-operated at least once a month.
- c. Faulty civil structures and damages must be regularly (min. 6 months) repaired.
- d. The water conveyance system and the powerhouse and tailrace area must be checked thoroughly after flood flows, especially if the plant was shut down during the flood.

Sand trap, gravel trap and fore bay must be checked for sediments at least monthly and flushed if required.

### **5.2.2 Electro-Mechanical Equipment**

- b. The bearings should be manually checked for vibration and excess temperature at least twice a week unless the control system provides automatic temperature monitoring.. The temperature of the bearing housing of turbines and generators should not exceed 60° or the limit prescribed by the manufacturer. Manufacturer's maintenance manual takes precedence over the following rules.

- c. The play of bearings must not exceed 0.15% of shaft diameter. Roller and ball bearings should be checked regularly for abnormal operation noise. This applies to both turbine and generator.
- d. The play of guide vane shafts shall not exceed 0.15mm.
- e. All fastener connections of the foundation; turbine, generator and other vibrating parts should be checked 1 week and 4 weeks after commissioning or any assembly work. Regular checks shall be made every 6 months.
- f. Abnormal leakages are an indication for changing the seals or other worn out parts. Leakages may also indicate loose fasteners.
- g. The turbines should be dewatered and checked for abrasion damage on runner and nozzle / needle valve or guide vane once a year.
- h. The ventilator grill and air ducts of the generator are to be cleaned at least once in three months.
- i. All terminals of the generator, load controller, transformer, etc. shall be checked, cleaned and tightened where necessary once every three months.
- j. AVR box of generator and controller should be inspected if dust, insects or other dirt accumulated. Cables channels and cables must regularly be checked on damages produced by rats or other animals and insects.

Spare parts to be supplied by the e/m equipment supplier shall comprise all required parts to avoid long standstill of the site. Following parts are highly recommended: 10% of bolts, one set gaskets and seals, one set of bearings of turbine and generator, and other wearing parts like coupling rubbers or belts. Frequently failing electrical parts like rotating diodes of generator fuses as well shall be as well supplied.

## Standards and Guidelines

Sl. No.	Bureau of Indian Standard No.	Title
1	IS : 325 (1996)	Three-phase induction motors
2	IS : 1239 part 1 (2004)	Steel Tubes, Tubulars and Other Wrought Steel Fittings - Specification - Part 1 : Steel Tubes
3	IS : 1239 part 2 (1992)	Mild steel tubes, tubulars and other wrought steel fittings, Part 2 Mild steel tubulars and other wrought steel pipe fittings
4	IS : 3589 (2001)	Steel Pipes for Water and Sewage (168.3 to 2 540 mm Outside Diameter) - Specification
5	IS : 4247 (Part1): 1993	Code of practice for structural design of surface hydroelectric power stations: Part 1 Data for design (third revision)
6	IS: 2309 (1989)	Code of practice for the protection of buildings and allied structures against lightning
7	IS: 4247(Part2)(1992)	Code of practice for structural design of surface hydroelectric power stations: Part 2 superstructure (second revision)
8	IS: 4247 (Part 3) (1998)	Code of practice for structural design of Substructure (second revision)
9	IS: 4722 (2001)	Rotating Electrical Machines
10	IS : 12800(Part 3) (1991)	Guidelines for selection of turbines preliminary dimensioning and layout of surface hydroelectric power house
11	IS : 5330 (1984)	Criteria for design of anchor blocks for penstocks with expansion joints (first revision)
12	IS : 7396 (Part 2) (1985)	Criteria for hydraulic design of surge tanks: Part 1 simple, restricted orifice and differential surge tanks (first revision)
13	IS : 7516 (1992)	Code of practice for open power channels (first revision)
14	IS : 11625 (1986)	Criteria for hydraulic design of penstocks
15	IS : 11639 (Part 1) (1986)	Criteria for structural design of penstocks: part 1 surface penstocks
16	IS : 7114 (1987)	Criteria for hydraulic design of cross regulators for canals
17	IS : 10430 (2000)	Criteria for design of lined canals and guidelines for selection of type of lining (first revision)
18	IS : 10137 (1982)	Guidelines for selection of spillways and energy dissipators
19	IS : 7720 (1991)	Criteria for investigation, planning and layout of barrages and weirs (first revision)
20	IS : 12065(Part1/Sec0) (1987 )	Permissible limits of noise level for rotating

		electrical machines
21	IS :12824(Part0/Sec0): 1989 IEC 34-(1983)	Type of duty and classes of rating assigned to rotating electrical machines
22	IS : 14197/(Part0/Sec0)/1994/IEC -60193 (1999)	Code for model acceptance tests of hydraulic turbines
23	IS : 4889(Part0/Sec0) (1968)	Method of determination of efficiency of rotating electrical machines
24	IS : 60041:2000/IEC 6004 (1991)	Field acceptance tests to determine the hydraulic performance of turbines, storage pumps and pump turbines
25	IS : 7132(Part 0/Sec 0) (1973)	Guide for testing synchronous machines
26	IS : 14458(Part 1) (1998)	Guidelines for retaining wall for hill area: Part 1 selection of type of wall
27	IS : 14458(Part 2) (1997)	Guidelines for retaining wall for hill area: Part 2 Design of retaining/breast walls
28	IS : 456 (2000)	Code of practice for plain and reinforced concrete (fourth revision) Amendment No.1)
29	SP : 34 (1987)	Handbook on concrete reinforcement and detailing
30	IS : 10118(Part 1/Sec 0) (1982)	Code of practice for selection, installation and maintenance of switchgear and controlgear: part 1 General
31	IS : 12729 (1988)	Common specification for high voltage switchgear and controlgear standards (first revision)
32	IS : 10028(Part 1/Sec 0) (1985)	Code of practice for selection, installation and maintenance of transformers: Part 1 Selection
33	IS : 5613 (Part 1/Sec 1) (1985)	Code of practice for design, installation and maintenance of overhead power lines: Part 1 Lines upto and including 11kV, Section 1 Design (first revision)
34	SP : 30 (1985)	National Electrical Code
35	Indian Electric Rules (1956), CEA Electricity Act 2003, Government of India	
36	CEA (Central Electricity Authority)	Guidelines for Development of Small Hydroelectric Schemes - 1982
<b>REC Specifications and Construction Standards, Rural Electrification Corporation Ltd. (Govt. of India)</b>		
37	Specification 51/1987	Epoxy based protective paint
38	Specification 26/1987	PVC insulated LT cables
39	Specification 27/1983	PVS insulated LT service cables with 40 embedded bearer wire
40	Construction Standards/ 1994	415/240 volt lines, 11 kV lines, 11 kV/433-250 distribution sub station
<b>International Electro Mechanical Commission (IEC) Standards</b>		
41	IEC-61116(1992)	Electro mechanical Equipment for Small Hydro
42	IEC-60545 (1978)	Guide for commissioning, operation and maintenance of hydraulic turbines

## Sample Design Criteria

*Following design criteria may be adopted for designing the Micro Hydro Power Project*

No. of Houses	=	N
Power allocation for a house (P)	>	200 Watts(as per need and availability)
Distribution loss (L)	<	10% of net generation
Allowance for future demand growth (G)	=	20% of present demand
Community Use(U)		+ 20 % of present demand
Design capacity (C)	>	$[N*P]*(1+G)*(1+L) / 1000$ kW
Minimum power generation	>	25% of design capacity (0.25*C) kW
Overall Efficiency	>	60%
Head (H)	=	Level difference
Design flow (F)	>	$[C*H*0.6] / 1000$ litre/s
Base flow	>	Design flow (F)
Flow released to the natural stream during lean season	>	20% of design flow

**Recommended spares**

1. Bearings
2. Lubricants like multipurpose grease and oils in dust free containers
3. Instruments ( voltmeter, pressure gauge,etc)
4. Bolts and nuts
5. Fuses, MCBs and ELCBs
6. Cable connectors
7. Lightning arrestors
8. Ballast heaters
9. AVR
10. Gaskets, O rings for all flange joints
11. Two lengths of penstock
12. V-belts and couplings
13. Oil seals, rubber packing, gland ropes (one set)
14. One type each of pipe fitting, connector, ferrules washer etc of hydraulic and water pipe lines
15. One card of each type of electronic controller/ governor/ protection if applicable
16. One set of indicating lamps and LEDs

**Recommended tools**

- a. A set of open-ended spanners
- b. Flat and cross-head screwdrivers
- c. Grease gun
- d. Bearing puller
- e. Tool rack to neatly place the tools
- f. Emergency rechargeable lights
- g. Digital Multimeter, Tong Tester
- h. Special tools like chain-pulleys, slings, nylon rope etc
- i. Test lamp and Tester
- j. Special tools required to dismantle and assemble turbine parts
- k. Tap and die set
- l. Feeler gauges
- m. Bench vice, Hammer, Hacksaw and 1m x 2m Table
- n. Dial gauge
- o. Spirit level

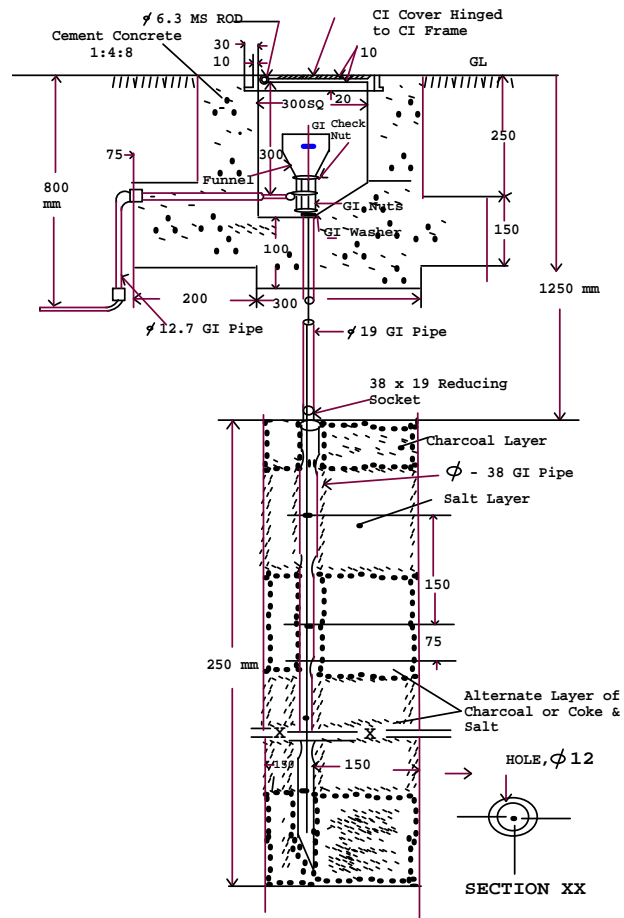

**Fig. 5 (a) A Typical Illustration of Pipe Earth Electrode**

Note-Three and four buckets of water to be poured into sump every few days to keep the soil surrounding the earth pipe permanently moist.

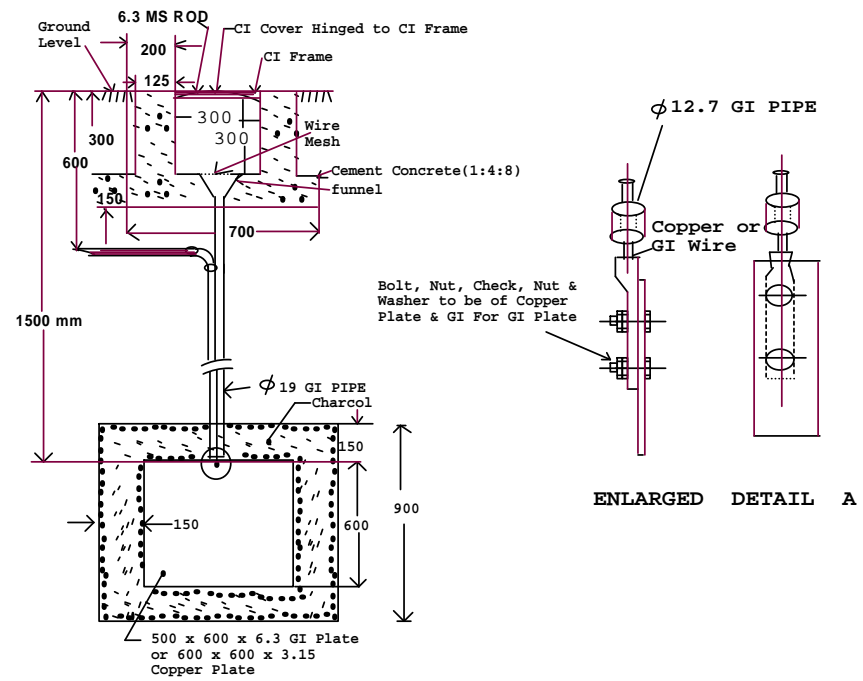
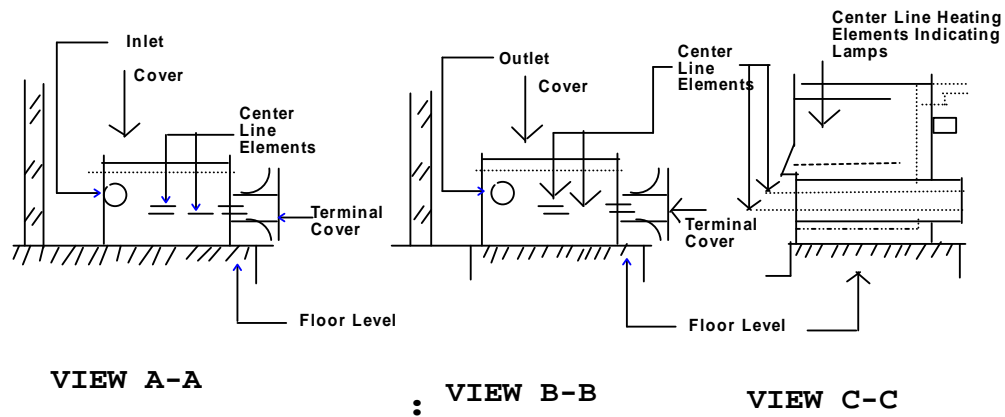
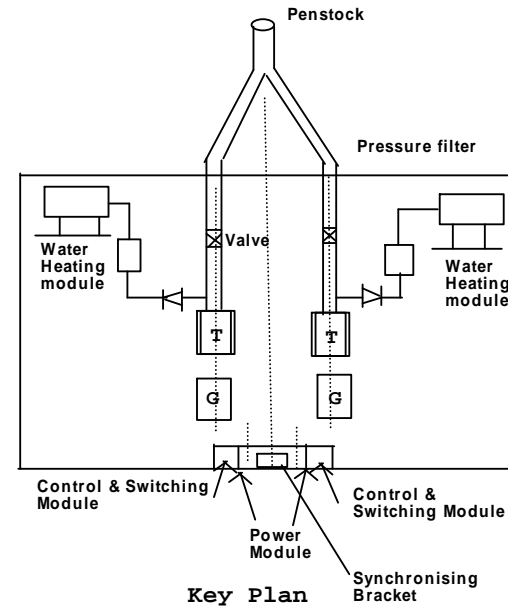
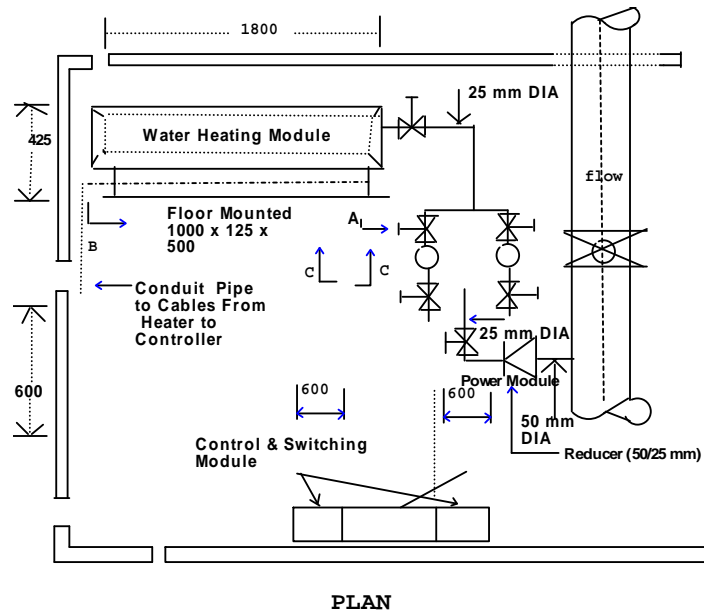

**Fig. 5 (b) Typical Illustration of Pipe Earth Electrode**

Note-Three and four buckets of water to be poured into sump every few days to keep the soil surrounding the earth plate permanently moist.

ALL DIMENSIONS IN MM  
(SOURCE:NATIONAL ELECTRICAL CODE)





**NOTE**  
All Dimensions in mm

Figure 6 : Ballast Load Hot Water System

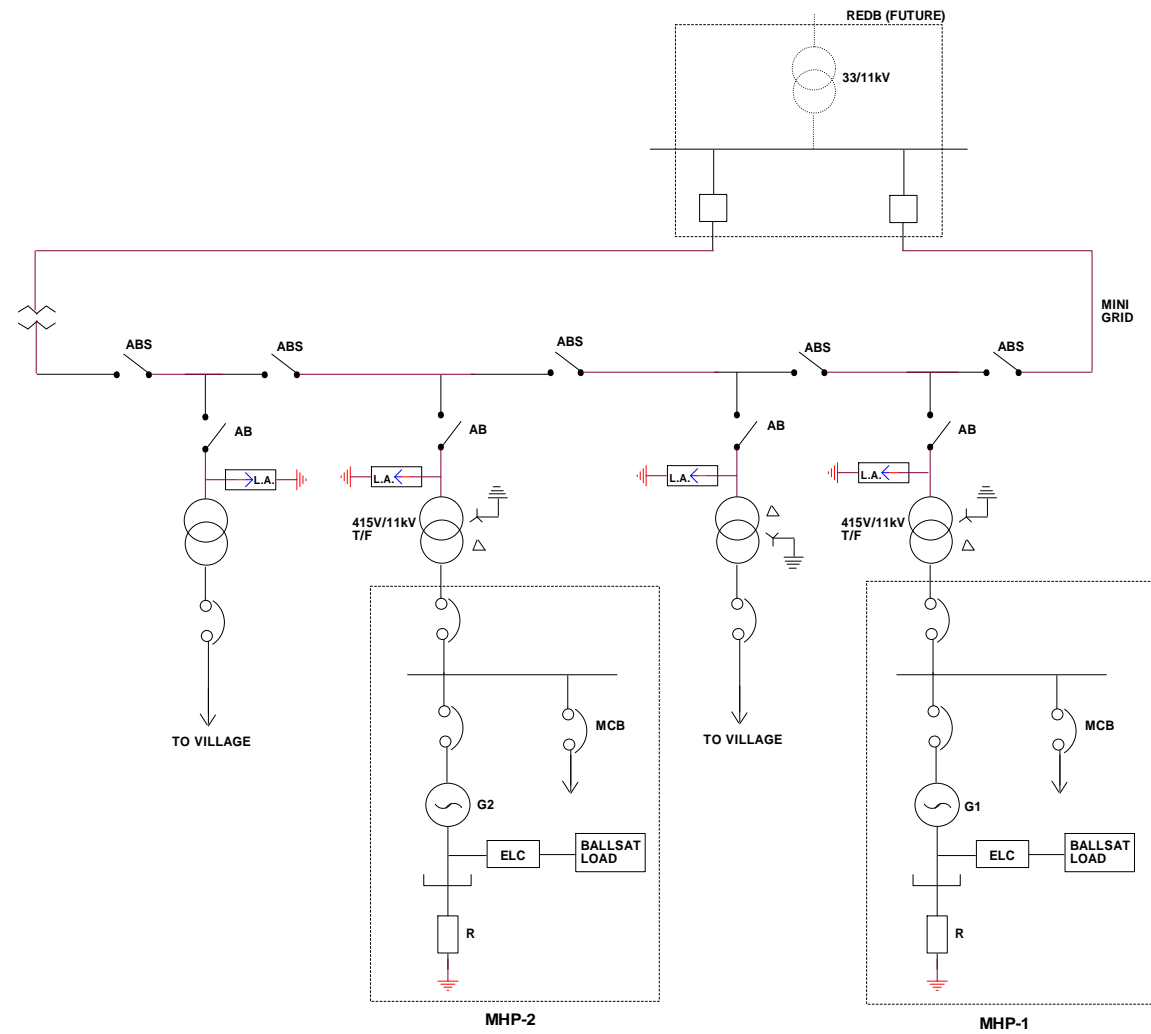

- NOTES**
1. MICRO HYDEL AS PER SINGLE LINE DIAGRAM FIGURE1
  2. 11KV AIR BREAK SWITCHES AS REC SPEC. 43/1987; IS: 9920  
LINE SECTIONALISER AS PER REC SPEC. 44/1987
  3. RECOMMENDED AIR BREAK SWITCHES
  4. SECTIONALIZING SWITCHES BE 200A/400A CAPACITY WITH REC WITH HRC FUSES AS PER REC STANDARD F-
  5. 415V/11KV TRANSFORMER BE DRY TYPE AS PER REC SPEC. 30/1984

**Figure 7: A Typical Mini Micro Hydro Mini Grid Single line Diagram**

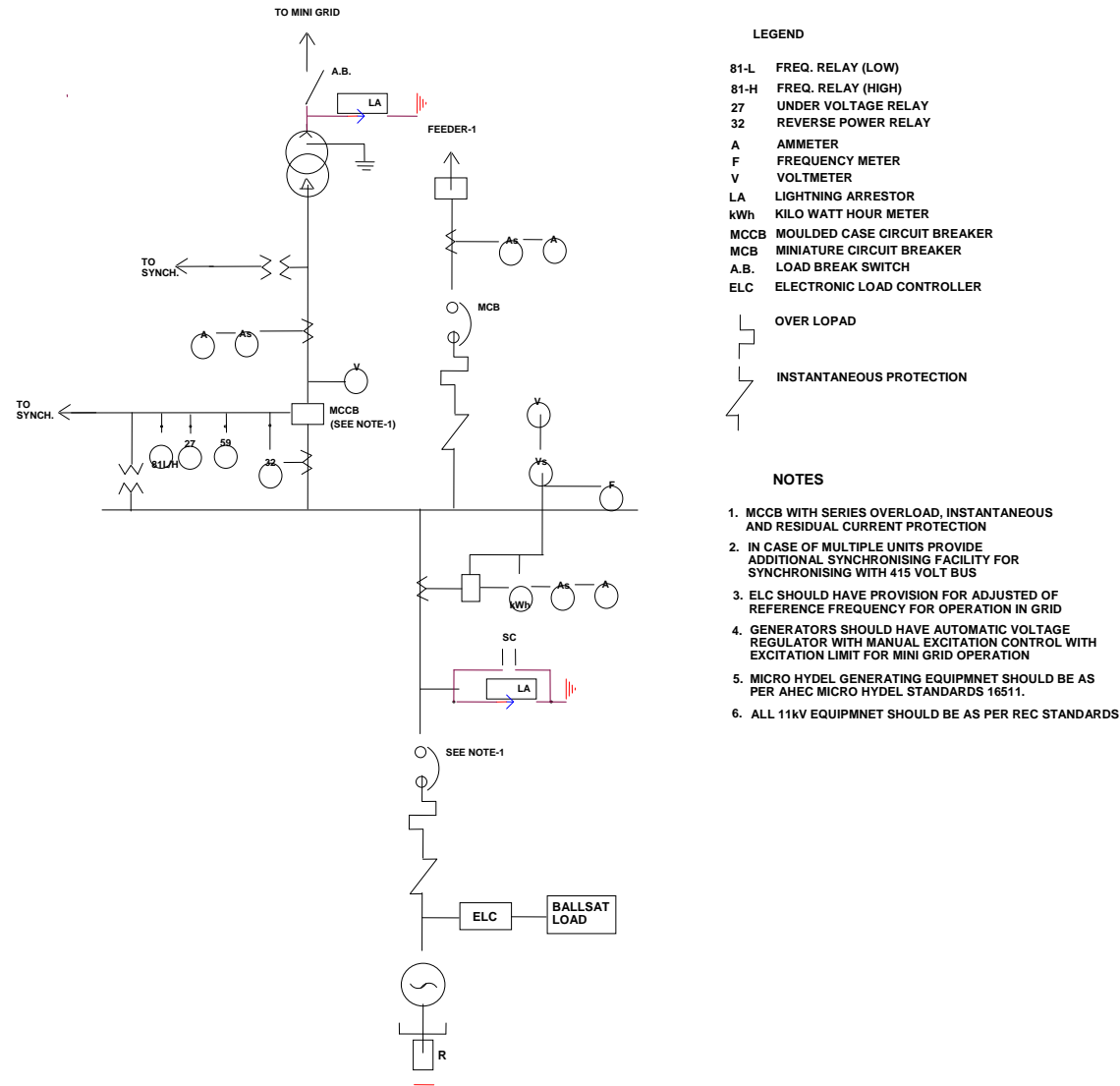

**Figure 8: A Typical Metering, Relaying and Interconnection with Mini Grid**

**NATIONAL COMMITTEE FOR MICRO HYDRO QUALITY**  
**STANDARDS**

**Chairman**

1. **Prof. J.D. Sharma**  
Electrical Engineering Department,  
IIT, Roorkee  
Roorkee, UA 247667  
**E-mail:** [jaydsfee@iitr.ernet.in](mailto:jaydsfee@iitr.ernet.in)

7. **Mr. S. Odyuo,**  
Executive Engineer,  
Department of Irrigation and Flood  
Control,POU, NEPED Post Box 231,  
Kohima, **Nagaland**  
**E-mail:** [odyuosnet@yahoo.com](mailto:odyuosnet@yahoo.com)

**Members**

2. **Dr. P. Saxena,**  
Director,  
Ministry of Non-Conventional  
Energy Sources,  
Block No. 14, C.G.O. Complex,  
Lodi Road, **New Delhi – 110 003**  
**Email:** [psaxena\\_98@yahoo.com](mailto:psaxena_98@yahoo.com)

8. **Mr. R.K. Verma,**  
Chief Executive,  
Sai Engg. Foundation,  
Sai Bhawan,  
**New Shimla – 171 009 (H.P.)**

3. **Mr. Anil K. Chopra,**  
Director,  
Ministry of Non-Conventional  
Energy Sources,  
Block No. 14, C.G.O. Complex,  
Lodi Road, **New Delhi – 110 003**  
Email : [akchopra@hub.nic.in](mailto:akchopra@hub.nic.in)

9. **Mr. V. Ramasubramanian,**  
Managing Director,  
Sahyadri Energy Systems Private  
Limited,E-2422, Sahakara Nagar,  
**Bangalore – 560 092**  
**Email:** [rams@sahyadrienergy.com](mailto:rams@sahyadrienergy.com)

4. **Mr. A.K. Tyagi,**  
Dy Chief Project Officer,  
Uttaranchal Renewable Energy  
Development Agency  
Urja Park Campus, Industrial Area,  
Patel Nagar, **Dehradun – 248 001**  
Email: [aruntygi@yahoo.com](mailto:aruntygi@yahoo.com)

10. **Mr. Sonam Dawa,**  
Advisor,Ladakh Ecological  
Development Group,  
Karzoo,**Leh – 194 101**  
**Email:** [ledeg@sancharnet.in](mailto:ledeg@sancharnet.in)

5. **Prof. O.D. Thapar,**  
Former Professor Roorkee  
Post Box No. 67,  
**Roorkee – 247 667**

11. **Mr. P.D. Nair, FIE**  
Managing Director,  
Viyyat Power Pvt. Ltd.,  
Viyyat-Kaushubham,  
Karityavattom P.O.  
**Trivandrum – 695 581Kerela**  
**E-mail:** [pdnair@rediffmail.com](mailto:pdnair@rediffmail.com)

6. **Mr. Marki Loya**  
Director,  
Arunachal Pradesh Energy  
Development Agency,  
Land Survey Hostel Bldg. (1 Floor)  
P.O. Box 141, **Itanagar – 791 111**  
**E-mail:** [apedrtar@sancharnet.in](mailto:apedrtar@sancharnet.in),

12. **Mr. A.K. Goel,**  
M/s Small Hydro Engineers Consultant  
Pvt. Ltd., B 173, Sector 41,  
**Noida – 201 301**  
**E-mail:** [akgoel@aleomanali.com](mailto:akgoel@aleomanali.com)

13. **Mr. K.J. Dinesh,**  
General Manager – Projects  
LANCO GROUP  
UGF, Antriksh BhawaN,  
22, K.G. Marg, New Delhi – 110 001  
E-mail: [dinesh@lancogroup.com](mailto:dinesh@lancogroup.com)
14. **Mr. K.C. Arora,**  
Pentaflo Hydro Engineers,  
L-25, LGF , Kalkaji,  
New Delhi – 110 019  
Email: [kcarora@pentaflo.com](mailto:kcarora@pentaflo.com)
15. **Mr. T.K. Modak,**  
General Manager,  
M/s Jyoti Ltd.,  
50 Hanuman Road,  
New Delhi – 110 001  
E-mail: [jyotidelhi@vsnl.net](mailto:jyotidelhi@vsnl.net)
16. **Mr. S.K. Roy Choudhury,**  
M/s Ushamil Private Limited,  
A-292, Mahipalpur Extn. N.H.-8,  
New Delhi – 110 037  
E-mail: [ushmil@rediffmail.com](mailto:ushmil@rediffmail.com)
17. **Mr. B.S. Saini,**  
Gita Flow Pumps India Pvt. Ltd.,  
Gita Compound, Paper Mill Road,  
Saharanpur – 247 001  
E-mail: [gitalflo@hotmail.com](mailto:gitalflo@hotmail.com)
18. **Dr. J.T. Khirsagar,**  
Chief Engineer (Design)  
Kirloskar Bros. Ltd.,  
Hydel Projects Group,  
Chintan, 408/5, Mukund Nagar,  
Pune – 411 037  
E-mail: [jtkshirsagar@pnr.kbl.co.in](mailto:jtkshirsagar@pnr.kbl.co.in)
19. **Dr. R.P. Saini,**  
Senior Scientific Officer,  
AHEC, IIT Roorkee,  
Roorkee UA 247667  
E-mail: [rajsafah@iitr.ernet.in](mailto:rajsafah@iitr.ernet.in)

**Convener**

20. **Mr. Arun Kumar**  
Head,  
AHEC, IIT Roorkee  
Roorkee UA 247667  
E-mail: [akumafah@iitr.ernet.in](mailto:akumafah@iitr.ernet.in)